



International Soap Box Derby, Inc. Stock Car Plans

REVISED 3/2010

TABLE OF CONTENTS

Stock Division Program		Page 3
General Assembly Guidelines		Page 4
Help, Guidance & Support		Page 4
Supplies & Tools		Page 5
Let's Get Started	Floorboard Overview Legend	Page 6
Step One	Steering Stop Installation	Page 7
Step Two	Foot Brace Installation	Page 8
Step Three	Kingpin Installation	Page 9
Step Four	Steering Hardware Installation	Page 13
Step Five	Steering Cabling Installation	Page 16
Step Six	Stabilizer Installation	Page 21
Step Seven	Brake Pad Installation	Page 25
Step Eight	Brake Installation	Page 26
Step Nine	Weight Bolt Installation	Page 31
Step Ten	Airfoil Installation	Page 33
Step Eleven	Wheel Kit Installation	Page 35
Step Twelve	Shell Installation	Page 36
Step Thirteen	Signage, Lettering & Decoration	Page 38
Step Fourteen	Axle Alignment & Triangulation	Page 40
Step Fifteen	Assembly Checklist	Page 42
Tech Tips		
E20 – Optional Weights		Page 43
E21 – Optional Finishes		Page 46
E22 – Cockpit Foam		Page 47
E23 – Alignment		Page 48
E24 – Permitted Modifications		Page 50
Index		Page 51

STOCK DIVISION PROGRAM

Welcome to this exciting experience known as Soap Box Derby Racing! The International Soap Box Derby, Inc. program is designed to be an enjoyable learning experience for both the adult *and* the child. The program provides an opportunity to develop mutual respect and trust while demonstrating the importance of individual pride and sportsmanship.

The Stock car is a sit-up car designed to be driven in a lean forward position at all times for builders of a specific age range. The combined weight of the assembled car and the driver shall not exceed 200 pounds including the Z-Glas™ wheels. A combined weight of less than 200 pounds may be increased by the addition of owner provided weight.

The written rules, plans and regulations are designed for the participant to construct the car from a Stock Car Kit purchased from the International Soap Box Derby, Inc.

For rules and regulations, including eligibility and age range information, see the “Rule Book” available from the International Soap Box Derby, Inc. at http://www.aasbd.com/SBD_rules.htm. The established rules, plans and regulations shall be applicable to all races and events and shall be taken into account as to all issues involving the construction of a car. By participating in these events, all participants are deemed to have consented to the rules and authority of person who shall enforce the rules.

No expressed or implied warranties of any kind, including any warranty of safety, shall result from the publication or compliance with these rules, plans and regulations. In no event shall the International Soap Box Derby, Inc. be liable for any loss, indirect, special or consequential damages even if the International Soap Box Derby Inc. has notice of possibility of such damages. The International Soap Box Derby, Inc. makes no warranties, including any warranties of fitness for a particular purpose with respect to the publication or compliance with these rules, plans or regulations. In all situations, the rules and regulations promulgated by the International Soap Box Derby, Inc. shall govern and control over any conflicting provision in these plans.

Each participant understands and agrees that a prerequisite to competing in any Championship Race sanctioned by the International Soap Box Derby Inc. in Akron, Ohio, that the racer and his or her car shall undergo and pass inspection conducted at Akron, Ohio by the International Soap Box Derby Inc. Each participant further understands and agrees that such inspection shall be conducted using the manner and methods deemed appropriate by the International Soap Box Derby Inc. in its sole discretion to determine compliance with the rules, plans, regulations, Spirit of the Rules and specifications applicable to that division and that the decisions of the International Soap Box Derby Inc. and its officials regarding qualifications and disqualification in compliance with the rules, Spirit, plans, regulations and specifications applicable to that division shall be final and binding upon all parties.

GENERAL ASSEMBLY GUIDELINES

A parent, guardian or mentor is expected to help in the construction of the car. The parent, guardian or mentor must *not* build the car for the child, but instead share this educational experience by being present and giving help only when and if necessary.

This plan booklet shall be followed when assembling your car. The hardware provided in the International Soap Box Derby, Inc. Stock Car Kit must be used and assembled as shown in the latest rules, plans and specifications. No changes, modifications or additions, other than the inclusion or omission of specified optional parts, shall be made to the car. All new and existing Stock cars shall be updated to the latest set of rules and plans for the Stock division.

In the event there is any conflict between the written portions of this plan booklet and the pictures or diagrams, the written portions in all situations will control.

Replacement of all hardware, as well as optional parts, is available from the International Soap Box Derby, Inc. In general, replacement parts are sold in bags specified for each installation step of the car's construction and optional parts are available on a per item basis.

HELP, GUIDANCE & SUPPORT

Questions or inquiries for clarification pertaining to the rules, plans and/or regulations shall be directed primarily to your Local Race Director and/or Regional Director. The International Soap Box Derby, Inc. also offers a web site at www.aasbd.com that provides additional assistance to the parent, guardian, mentor and/or child. The website contains links to useful information such as the latest rules and plans, ordering kits or parts online, Local Race city Organization contact information and frequently asked questions to name a few. In addition, this website allows you to participate in an online message board with other racing enthusiasts!

If further explanation is needed, questions should be directed to the International Soap Box Derby, Inc. **National Control Board**. All questions or inquiries for clarification must be emailed to ncb@asbd.org or requested in writing, including the full name and contact information (address, phone number) of the participant, to:

International Soap Box Derby, Inc.
ATTN: National Control Board
P.O. Box 7225
Akron, Ohio 44306

Please note that a response to a specific participant's question may *not* apply to all other participants.

SUPPLIES & TOOLS

The following list of tools is a guideline to aid in the basic assembly of the Stock Car Kit. The International Soap Box Derby, Inc. does *not* provide these tools as part of the kit. Sources for these tools include, but are not limited to, hardware and automotive supply stores.

1. Screwdrivers
 - #2 Phillips screwdriver
 - Wide flat blade screwdriver
2. Wrenches or Sockets
 - 3/8" open-end box wrench
 - 7/16" open-end box wrench
 - 1/2" open-end box wrench
 - 9/16" open-end box wrench
3. Allen Wrenches
 - 5/64" Allen Wrench
4. Pliers
 - Standard Pliers
 - Wire Cutter Pliers
5. Measuring Tape
 - 10' minimum length
6. Hammer
 - Standard Hammer or Mallet
7. Soldering Iron with lead-free solder and flux
8. Support Boards
 - (2) 2 x 4 x 18" ±
9. Triangulation Materials
10. Feeler Gauges
11. "C" Clamps
12. Battery Powered Drill

The following list of tools or supplies is a guideline to aid in the basic finish of the Stock Car Kit. The International Soap Box Derby, Inc. does *not* provide these tools or supplies as part of the kit. Sources for these tools include, but are not limited to, hardware and automotive supply stores.

1. Metal Cleaning Materials
 - Steel wool
 - Non-metallic abrasive pad
2. Adhesive
 - Contact Cement
3. Tape
 - Electrical Tape
 - Clear Tape
4. Finishing
 - Automotive wax
 - Paint (See Tech Tips on Optional Finishes)

LET'S GET STARTED!

This is the Stock Floorboard Legend. This diagram will give you a brief overview of some of the steps in the assembly process. Each step listed on this page will be explored in greater detail in upcoming steps.

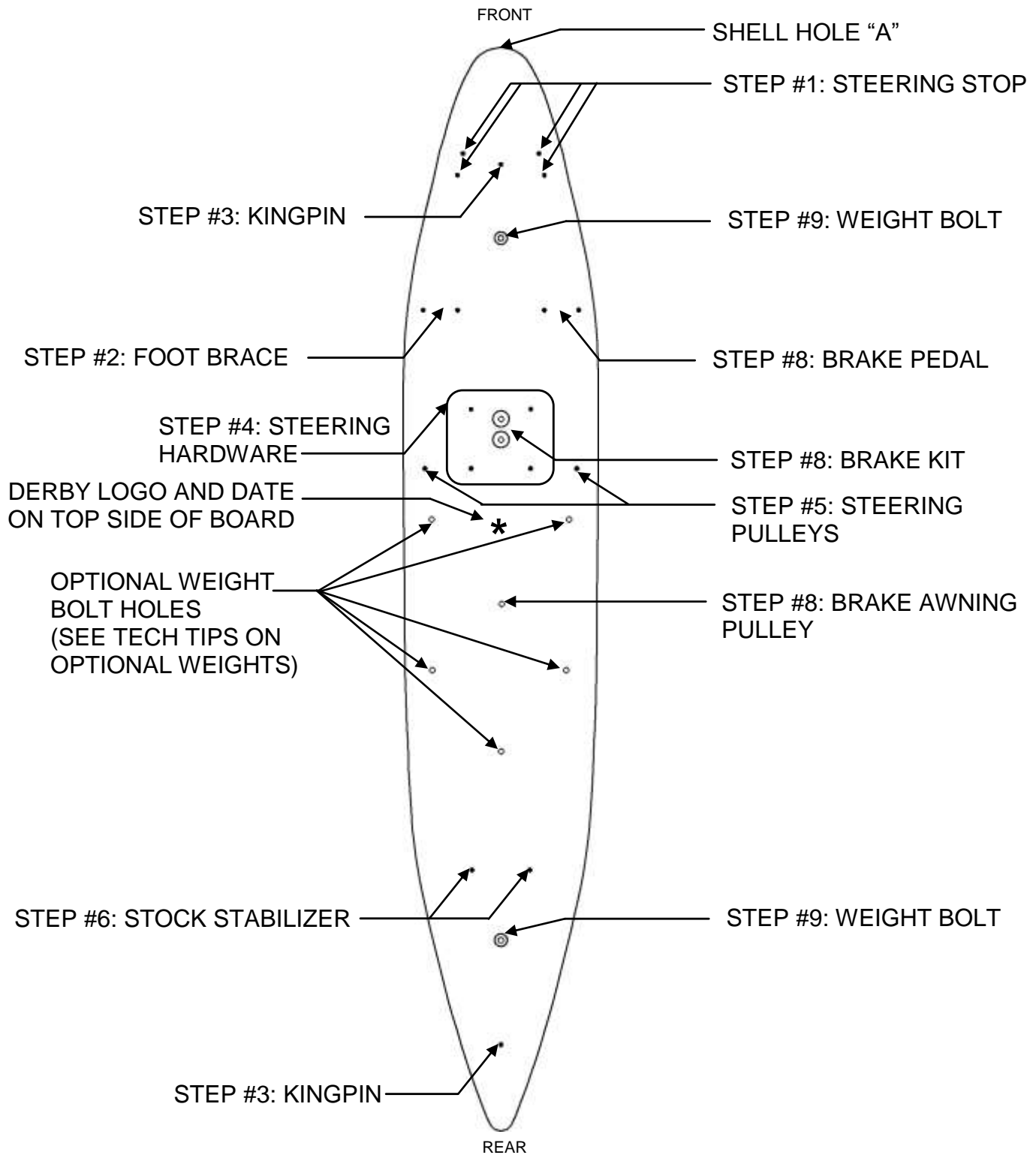

STOCK FLOORBOARD LEGEND

STEP ONE

Steering Stop Installation

Required Items: Steering Stop Bag, Floorboard, Tools

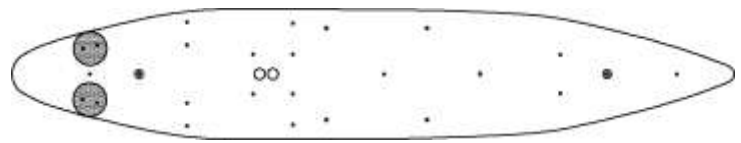
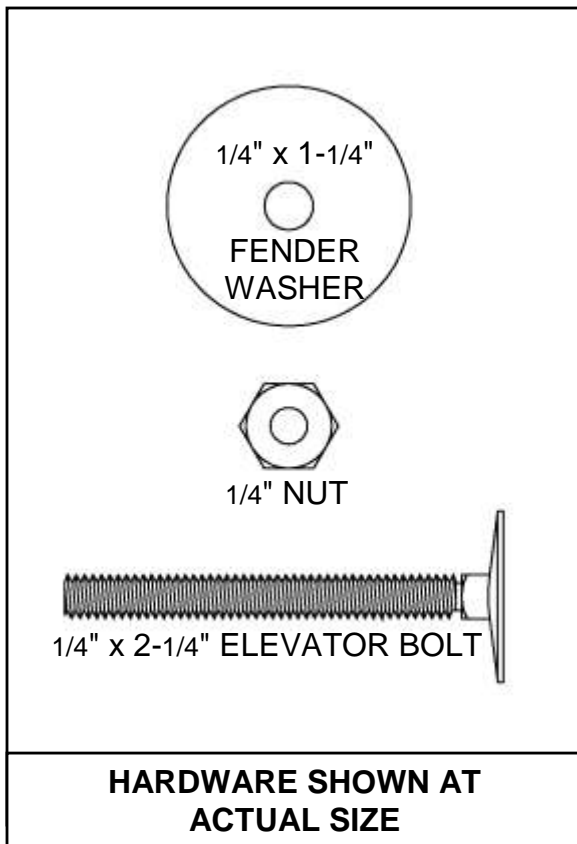

**Steering Stop
(Legend Area Highlighted)**

Steering Stop Installation

- 1.1 Insert one 1/4" x 2-1/4" elevator bolt through the floorboard bottom at a steering stop hole location and press through the floorboard. See legend for location of holes.
- 1.2 Place a 1/4" x 1-1/4" fender washer on the elevator bolt on top of the floorboard.
- 1.3 Install 1/4" nut on 1/4" x 1-1/4" fender washer. Tighten nut until elevator bolt is drawn in flush with bottom of floorboard. Install two additional 1/4" nuts for a total of three. See Photo # 1.3
- 1.4 Repeat Steps 1.1 through 1.3 for the other three steering stop locations. See Photo # 1.4

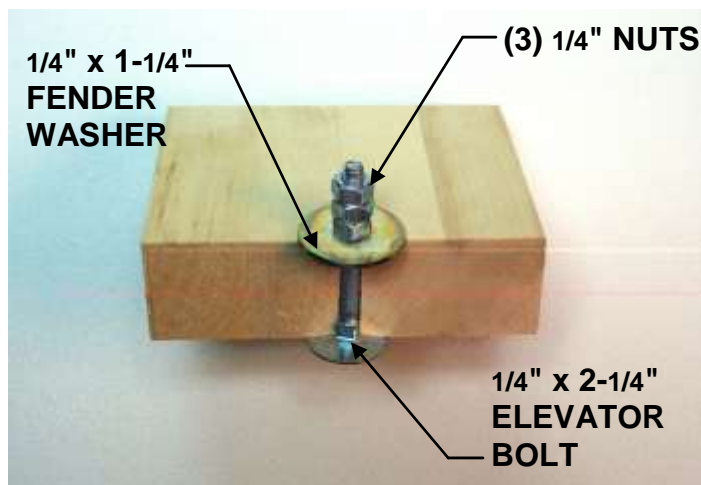

Photo # 1.3

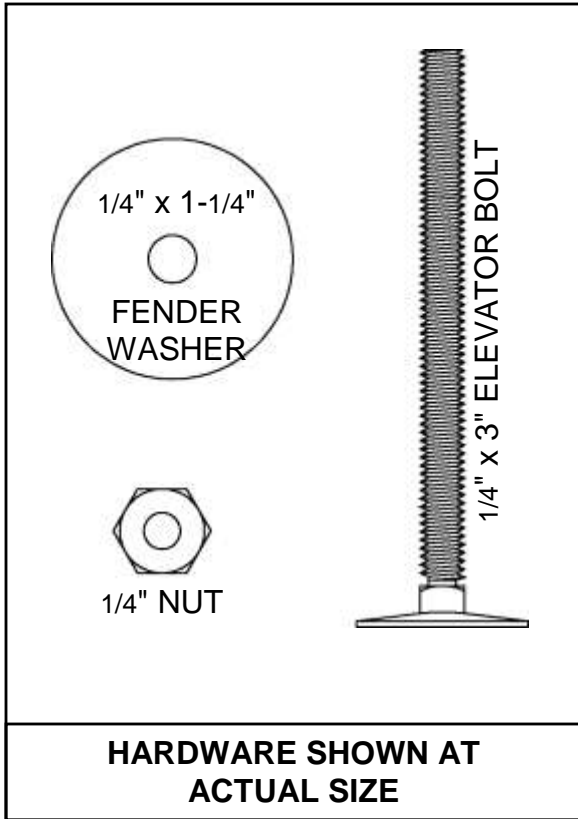

Photo # 1.4

STEP TWO

Foot Brace Installation

Required Items: Foot Brace Bag, Floorboard, Foot Brace, Tools



**Foot Brace
(Legend Area Highlighted)**

Foot Brace Installation

***See Tech Tip E24.3**

- 2.1 Insert one 1/4" x 3" elevator bolt through the floorboard bottom at a foot brace hole location and press through the floorboard. See legend for location of holes.
- 2.2 Place foot brace on the elevator bolt.
- 2.3 Place a 1/4" x 1-1/4" fender washer on the elevator bolt on top of the foot brace.
- 2.4 Install 1/4" nut on 1/4" x 1-1/4" fender washer. See Photo # 2.4
- 2.5 Repeat Steps 2.1 through 2.4 for the second foot brace bolt location.
- 2.6 Tighten nuts until elevator bolts are drawn flush with bottom of the floorboard.

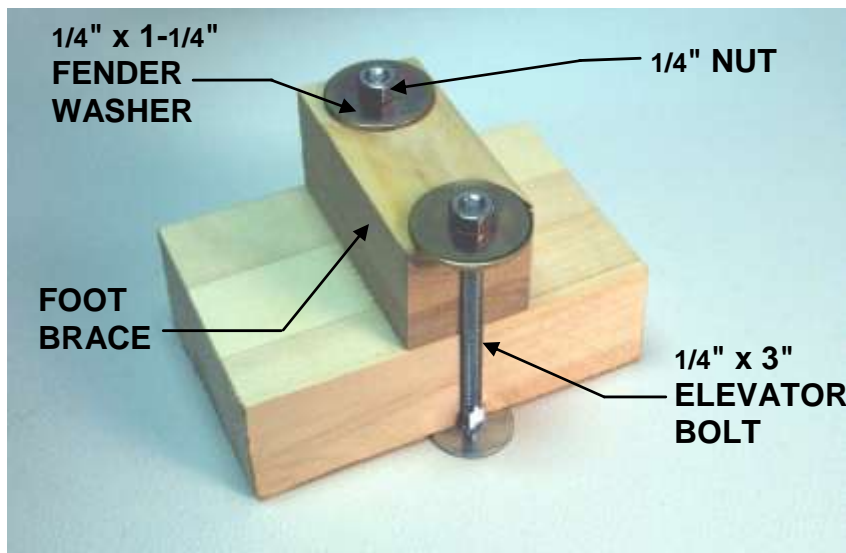
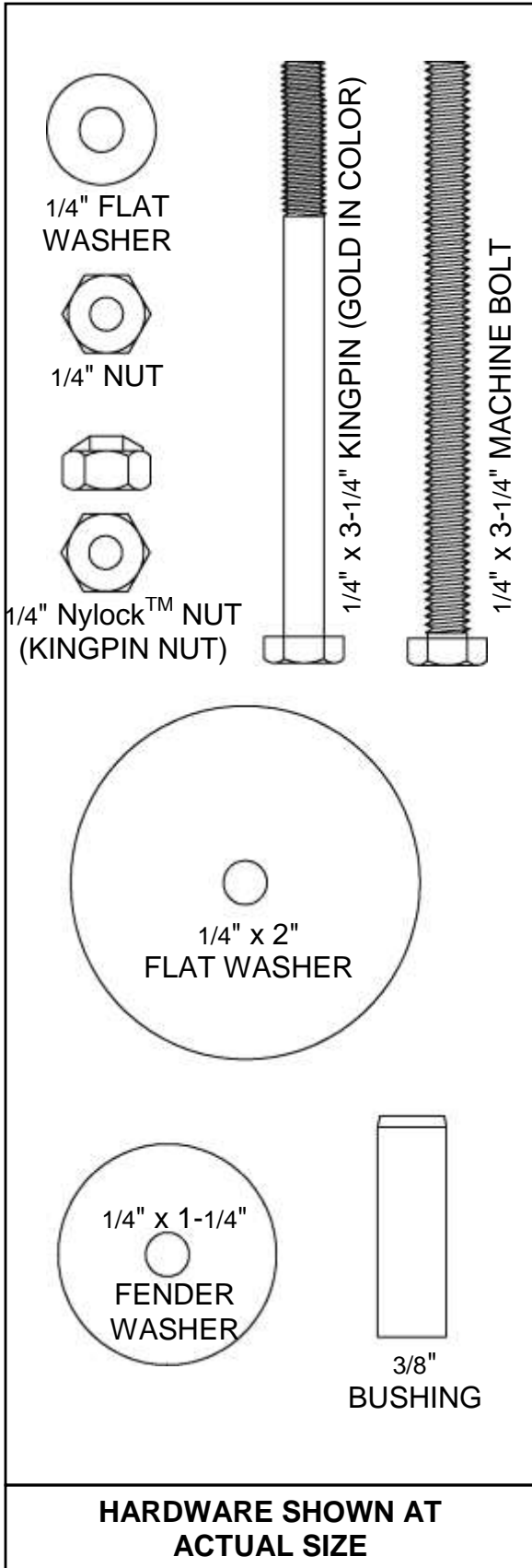

Photo # 2.4

STEP THREE

Kingpin Installation

Required Items: Kingpin Bag, Floorboard, Set of Axles, Tools



Bushing Installation
(Legend Area Highlighted)

Bushing Installation Sub-Assembly

*See Tech Tip E24.1

- 3.1 Place 1/4" x 1-1/4" fender washer on 1/4" x 3-1/4" machine bolt. Bolt is silver in color.
- 3.2 Place bushing with flat end against fender washer on the 1/4" x 3-1/4" machine bolt.
- 3.3 Insert assembly through the top or bottom of floorboard with beveled end of bushing against floorboard until bolt extends through opposite side of floorboard at kingpin location. See legend for location of holes.
- 3.4 Place a 1/4" x 1-1/4" fender washer on the machine bolt against the floorboard.
- 3.5 Install a 1/4" nut on 1/4" x 1-1/4" washer. See Photo # 3.5

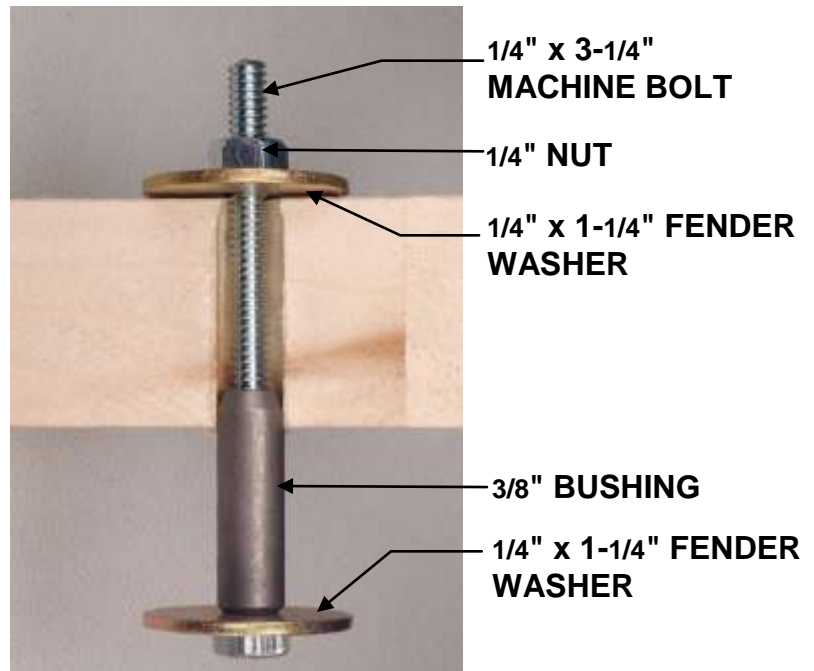

Photo # 3.5

Bushing Installation **Sub-Assembly Continued**

- 3.6 Tighten machine bolt assembly until bushing ends are flush with floorboard.
- 3.7 Remove 1/4" nut from 1/4" x 3-1/4" machine bolt and 1/4" x 1-1/4" fender washers. See Photo # 3.7
- 3.8 Repeat above steps for second kingpin bushing location.
- 3.9 Save 1/4" nut, 1/4" x 3-1/4" machine bolt and 1/4" x 1-1/4" fender washers for future use in Step Six.

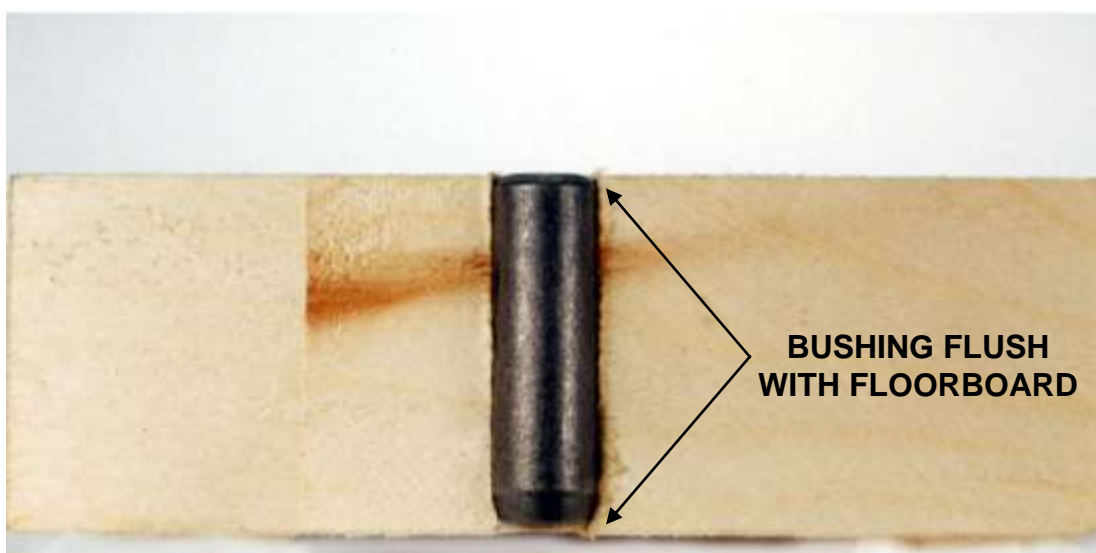

Photo # 3.7

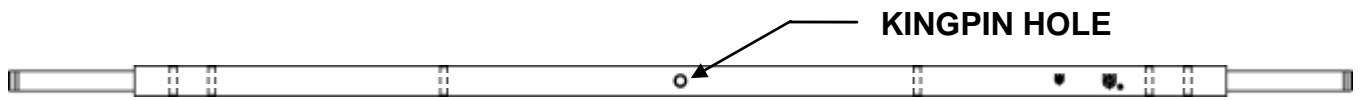

Figure # 3.15

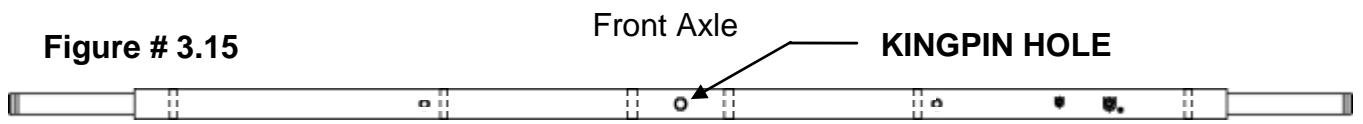

Figure # 3.18



Kingpin Installation
(Legend Area highlighted)

Kingpin Sub-Assembly

- 3.10 Place a 1/4" x 2" flat washer on 1/4" x 3-1/4" kingpin. Kingpin bolt is gold in color.
- 3.11 Insert kingpin/washer assembly through the bottom of floorboard at front axle location and press through floorboard. See legend for location of hole.
- 3.12 Place 1/4" x 2" flat washer on 1/4" x 3-1/4" kingpin.
- 3.13 Place 1/4" x 1-1/4" fender washer on top of the 1/4" x 2" flat washer.
- 3.14 Place 1/4" flat washer on top of the 1/4" x 1-1/4" fender washer.
- 3.15 Place front axle on 1/4" flat washer. See Figure # 3.15 for front axle identification.
- 3.16 Place two 1/4" flat washers on top of the axle.
- 3.17 Install 1/4" Nylock™ nut (kingpin nut). Tighten kingpin assembly. See Photo # 3.17

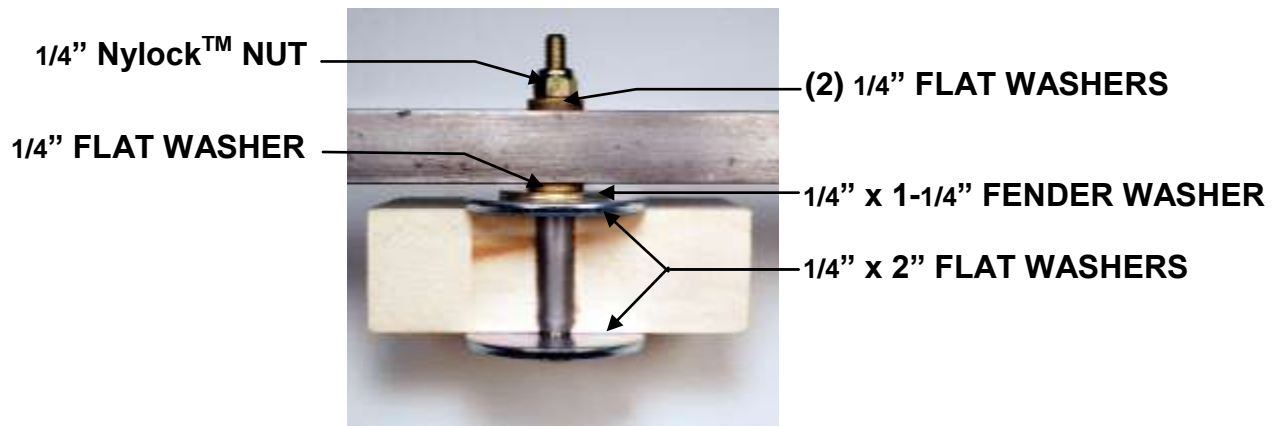

Photo # 3.17
(Rear Kingpin Washer Stack)

Kingpin Sub-Assembly Continued

- 3.18 Repeat steps 3.10 through 3.17 for rear kingpin installation. See Figure # 3.18 for rear axle identification.
- 3.19 Install a second 1/4" Nylock™ nut (kingpin nut) on front kingpin bolt assembly. See Photo # 3.19
- 3.20 Tighten kingpin assembly.

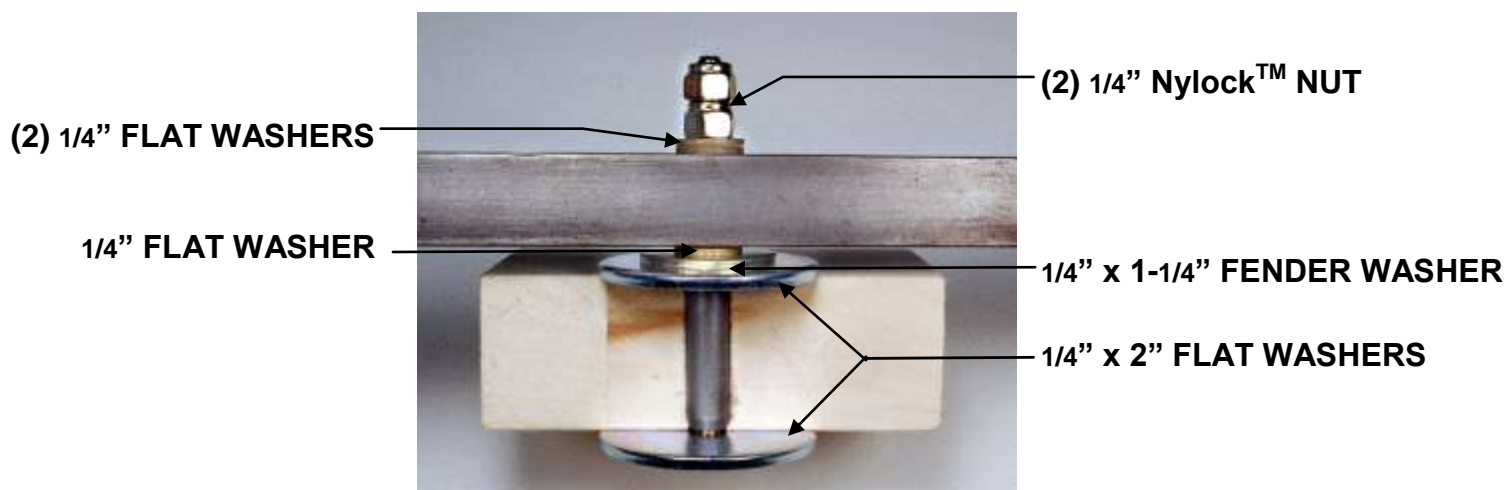
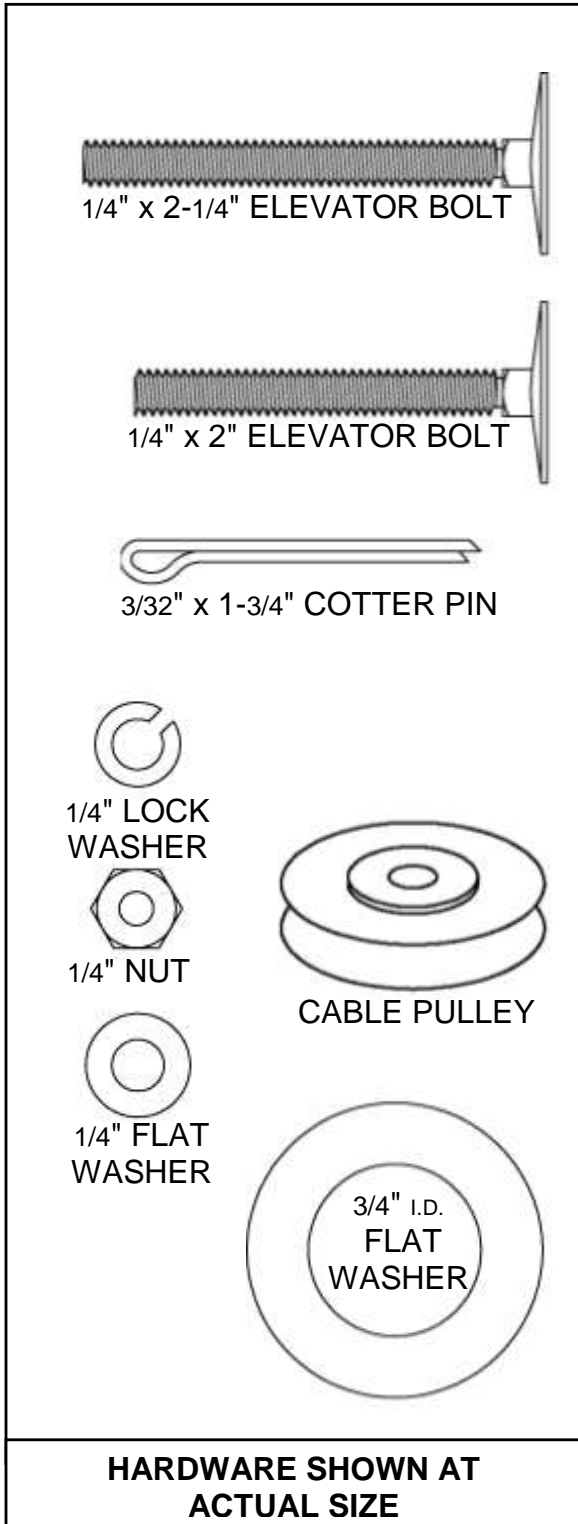

Photo # 3.19
(Front Kingpin Washer Stack)

STEP FOUR

Steering Hardware Installation

Required Items: Steering Bag, Floorboard, Brake/Steering Mount, Steering Wheel, Tools



**Brake/Steering Mount
(Legend Area Highlighted)**

Brake/Steering Mount Sub-Assembly

***See Tech Tip E24.2**

- 4.1 Insert a quarter or washer (provided by others) into the recessed floorboard area where the steering wheel shaft is to be installed. See Photo # 4.1
- 4.2 Align brake/steering mount with square tube over large hole drilled through floorboard and large round hole over quarter recessed floorboard area. See Photo # 4.2



Photo # 4.1



**Photo # 4.2
(Brake/Steering Mount –
Bolts shown for alignment only)**

Brake/Steering Mount Sub-Assembly Continued

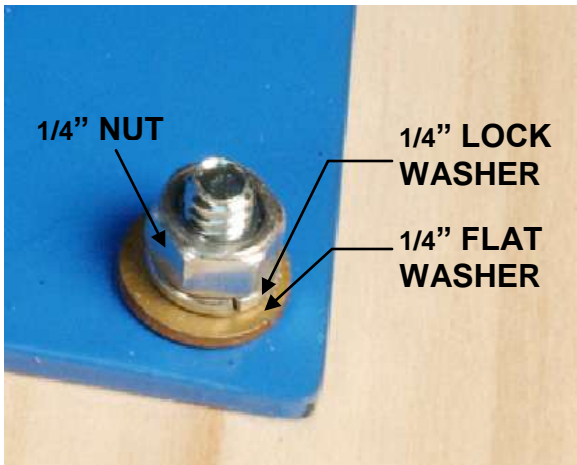

Photo # 4.7

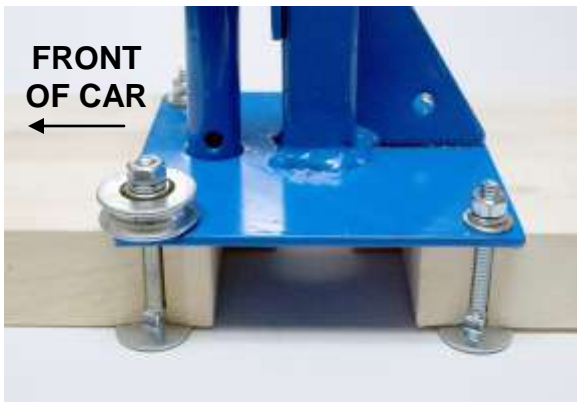

Photo # 4.13(a)

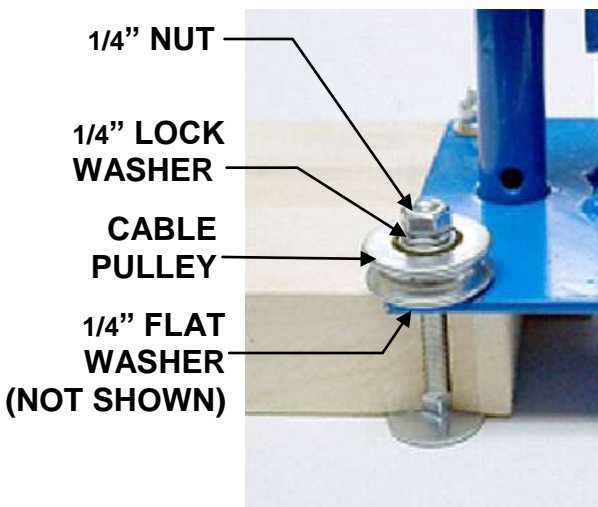

Photo # 4.13(b)

- 4.3 Insert one 1/4" x 2" elevator bolt through the floorboard bottom at rear brake/steering mount hole location and press through the floorboard. See floorboard legend for location of holes.
- 4.4 Place brake/steering mount on top of 1/4" x 2" elevator bolt.
- 4.5 Place 1/4" flat washer on the 1/4" x 2" elevator bolt on top of brake/steering mount.
- 4.6 Place 1/4" lock washer on the 1/4" x 2" elevator bolt on top of the brake/steering mount.
- 4.7 Install 1/4" nut on washers. See Photo # 4.7 **Do not completely tighten nut.**
- 4.8 Repeat Steps 4.3 through 4.7 for second rear brake/steering bolt location.
- 4.9 Insert one 1/4" x 2-1/4" elevator bolt through the floorboard bottom at front brake/steering mount hole location and press through the floorboard.
- 4.10 Place 1/4" flat washer on the top of 1/4" x 2-1/4" elevator bolt on top of brake/steering mount.
- 4.11 Place cable pulley on the 1/4" x 2-1/4" elevator bolt on top of brake/steering mount.
- 4.12 Place 1/4" lock washer on top of the cable pulley.
- 4.13 Install 1/4" nut on washer. See Photo # 4.13(a) & Photo # 4.13(b). **Do not completely tighten nut.**
- 4.14 Repeat Steps 4.9 through 4.13 for second front brake/steering bolt and cable pulley location.
- 4.15 Tighten all four nuts until bolts are drawn in flush with bottom of floorboard. Insert brake plunger through floorboard and brake/steering mount to check for proper alignment.

Steering Wheel Sub-Assembly

***See Tech Tip E24.4**

- 4.16 Insert steering wheel shaft through the round hole on the brake/steering mount.
- 4.17 Raise the steering wheel and slide the 3/4" I.D. flat washer on to the bottom of steering wheel shaft.
- 4.18 Push steering wheel down through brake/steering mount hole until shaft rests on top of quarter or washer installed in Step 4.1.
- 4.19 Push the 3/4" I.D. flat washer up against the brake/steering mount and insert 3/32" x 1-3/4" cotter pin through the upper steering wheel shaft hole. See Photo # 4.19
- 4.20 Bend end of cotter pin around steering wheel shaft.

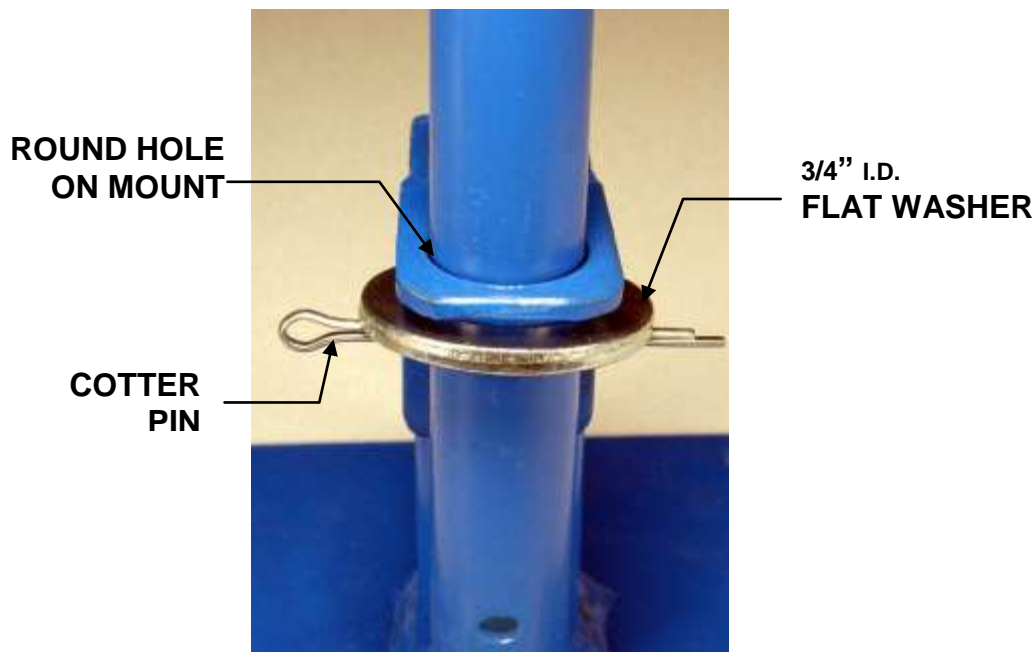
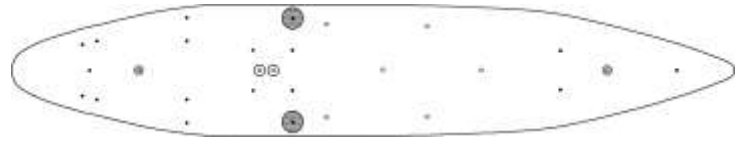
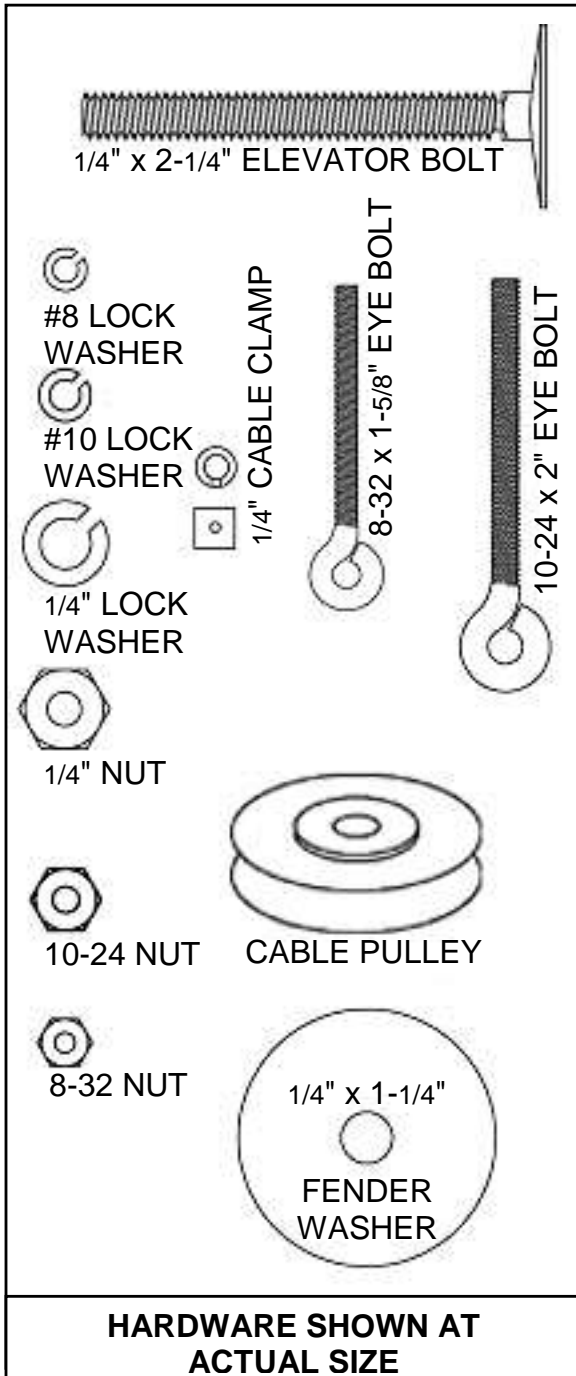

Photo # 4.19

STEP FIVE

Steering Cabling Installation

Required Items: Steering Cable Bag (complete with Steering Cable and Cable Adjuster), Floorboard, Steering Cable, Tools



Cable Pulley Sub-Assembly
(Legend Area Highlighted)

Cable Pulley Sub-Assembly

- 5.1 Insert one 1/4" x 2-1/4" elevator bolt through the floorboard bottom at a steering cable pulley hole location and press through the floorboard. See legend for location of holes.
- 5.2 Place a 1/4" x 1-1/4" fender washer on the 1/4" x 2-1/4" elevator bolt on top of the floorboard.
- 5.3 Place cable pulley on top of 1/4" x 1-1/4" fender washer.
- 5.4 Place 1/4" lock washer on top of the cable pulley.
- 5.5 Install 1/4" nut on 1/4" lock washer. See Photo # 5.5
- 5.6 Tighten nut until bolt is drawn flush with bottom of floorboard.
- 5.7 Repeat Steps 5.1 through 5.6 for second cable pulley location.

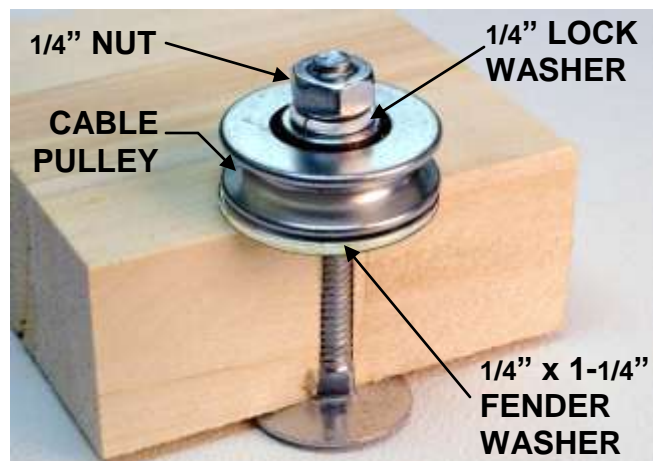

Photo # 5.5

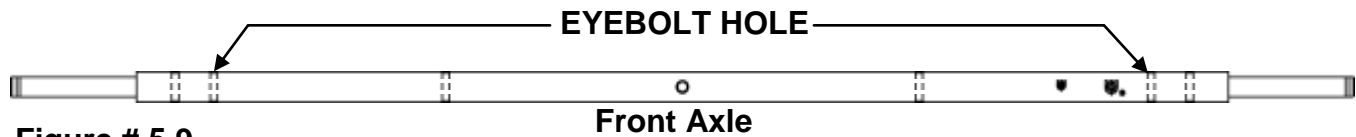

Figure # 5.9

Axle Eyebolt Sub-Assembly



Photo # 5.12

- 5.8 Install 10-24 nut on 10-24 x 2" eyebolt. Tighten the 10-24 nut to the end of threads on eye bolt.
- 5.9 Insert assembly through driver side of front axle at eye bolt location. See Figure # 5.9
- 5.10 Place a #10 lock washer on the bolt.
- 5.11 Install 10-24 nut on eyebolt assembly.
- 5.12 Tighten eyebolt assembly. See Photo # 5.12
- 5.13 Repeat Steps 5.8 through 5.12 for second axle eyebolt assembly.

Cable Adjuster Sub-Assembly



Photo # 5.17

- 5.14 Install 8-32 nut on 8-32 x 1-5/8" eyebolt.
- 5.15 Insert eyebolt through any of the three holes of cable adjuster and push through.
- 5.16 Place a #8 lock washer on 8-32 x 1-5/8" eyebolt.
- 5.17 Install 8-32 nut on # 8 lock washer. See Photo # 5.17
- 5.18 **Do not completely tighten assembly.** Further adjustments to occur in Step Fourteen.
- 5.19 Repeat Steps 5.14 through 5.18 for second cable adjuster assembly.

Steering Cable Sub-Assembly

***See Tech Tip E24.5**

- 5.20 Determine the center point of the steering cable by folding the cable in half.
- 5.21 Insert the two loose ends of the steering cable through the lower hole of the steering wheel shaft located horizontally above the floorboard.
- 5.22 Pull the two loose cable ends through the hole until an eyelet is formed at the center point of steering cable.
- 5.23 Wrap one loose end of cable around shaft 180 degrees and thread through eyelet. See Figure # 5.23
- 5.24 Wrap other loose cable end in other direction around shaft 180 degrees from first cable, and thread through eyelet.
- 5.25 Pull both cable ends to tighten eyelet to secure cable.
- 5.26 Continue first cable around steering shaft to a minimum of 360 degrees (at least one complete wrap). See Figure # 5.26
- 5.27 Center steering wheel and temporarily clamp steering wheel from turning.

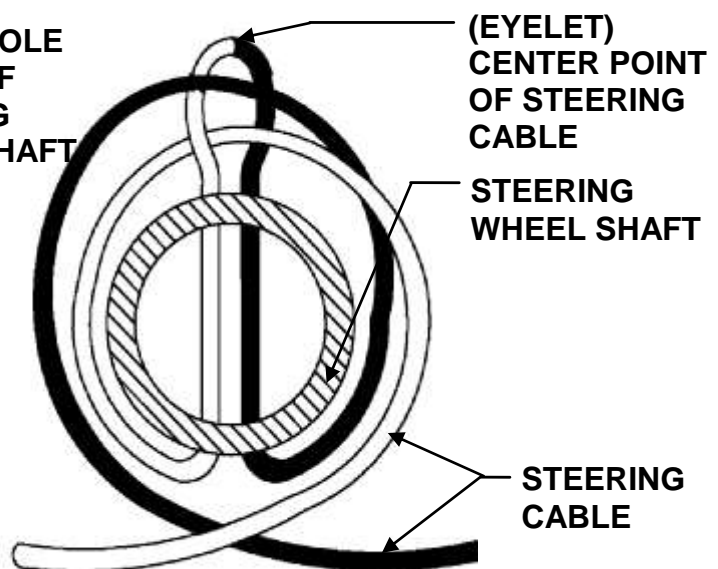
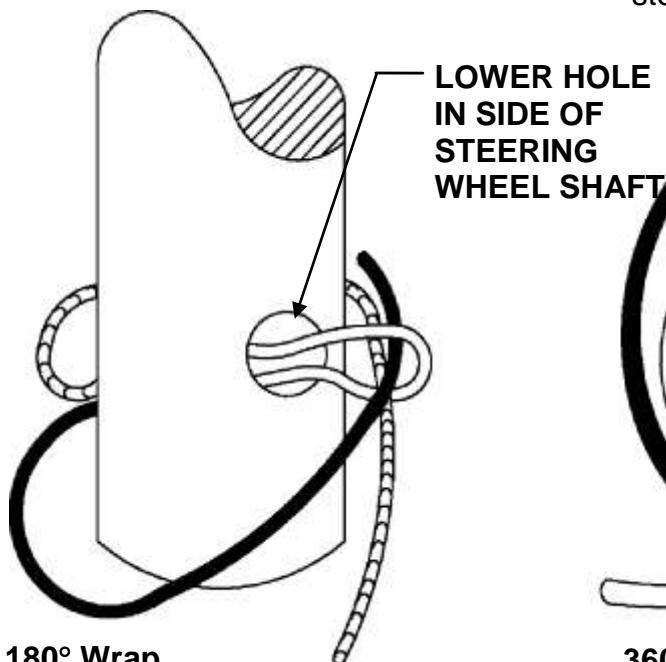

Steering Cable Sub-Assembly Continued



Photo # 5.31
(Cable Adjuster Assembly)

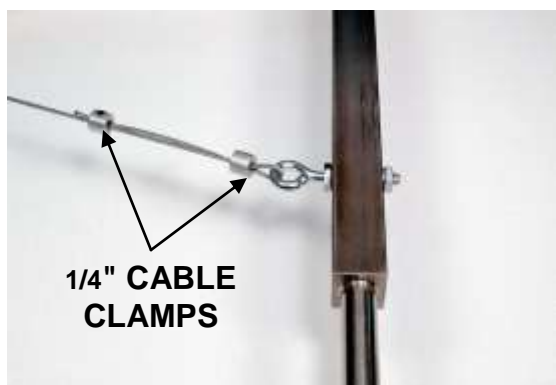

Photo # 5.36
(Front Axle Eyebolt Assembly)

- 5.28 Thread one cable around steering pulley located on brake/steering mount.
- 5.29 Thread this cable through the outside of one of the two remaining holes in the cable adjuster and into the inside of the cable adjuster.
- 5.30 Thread cable through eyebolt inside cable adjuster.
- 5.31 Thread cable through the remaining hole in the cable adjuster. See Photo # 5.31
- 5.32 Thread one cable around cable pulley located on floorboard.
- 5.33 Slide two 1/4" cable clamps on cable end.
- 5.34 Thread cable through the front axle eyebolt assembly.
- 5.35 Insert loose end of cable back through both cable clamps.
- 5.36 Pull cables tight and tighten both cable clamps with a 5/64" Allen Wrench. Cable clamps can be placed next to each other. No space between cable clamps is required. See Photo # 5.36

Steering Cable Sub-Assembly Continued

5.37 Repeat steps 5.28 through 5.36 for the other cable. Refer to Photos # 5.37(a) and 5.37(b) for cable route.

5.38 Adjust steering cables by adjusting 8-32 x 1-5/8" eyebolts in cable adjuster assemblies.

5.39 Secure both cable adjusters by tightening both of the 8-32 nuts. Cable adjusters may be located anywhere along the cable. Remove temporary steering wheel clamp from Step 5.27.

5.40 Test by turning steering wheel to the right while seated facing the front of the car. The front axle must turn to the right.

5.41 Excess steering cable may extend past second 1/4" cable clamp and may be removed by cutting. To avoid cable fraying it is recommended that solder be applied to a 1/4" +/- on either side of the proposed cut **prior to cutting**.

5.42 Steering cable adjustment to occur in future Step Fourteen.

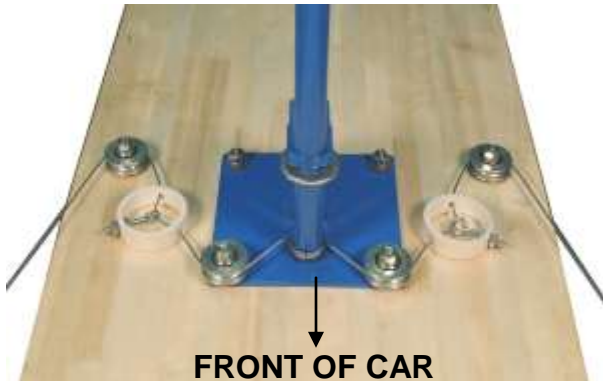

Photo # 5.37(a)

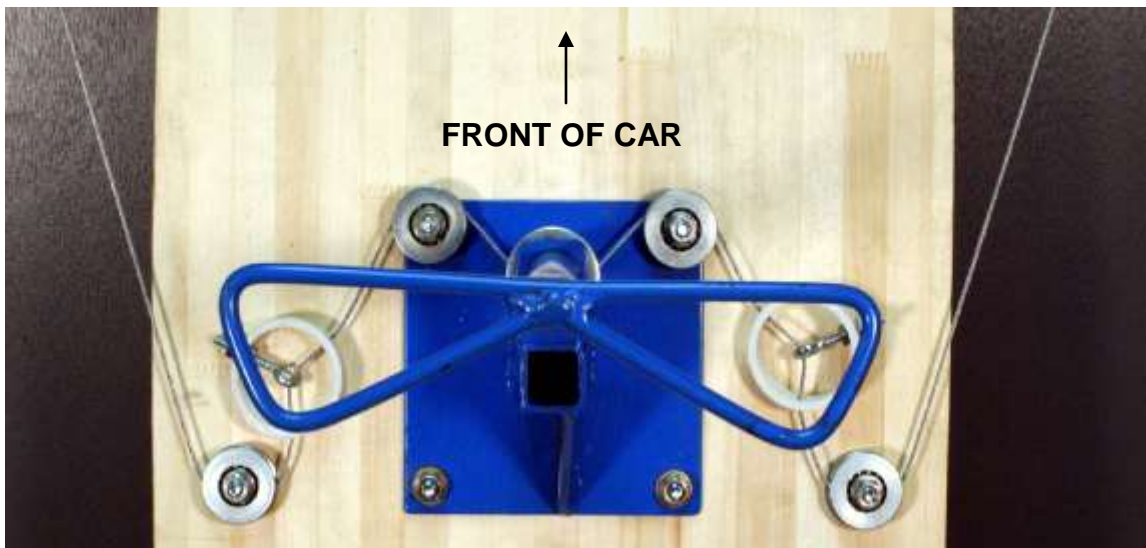
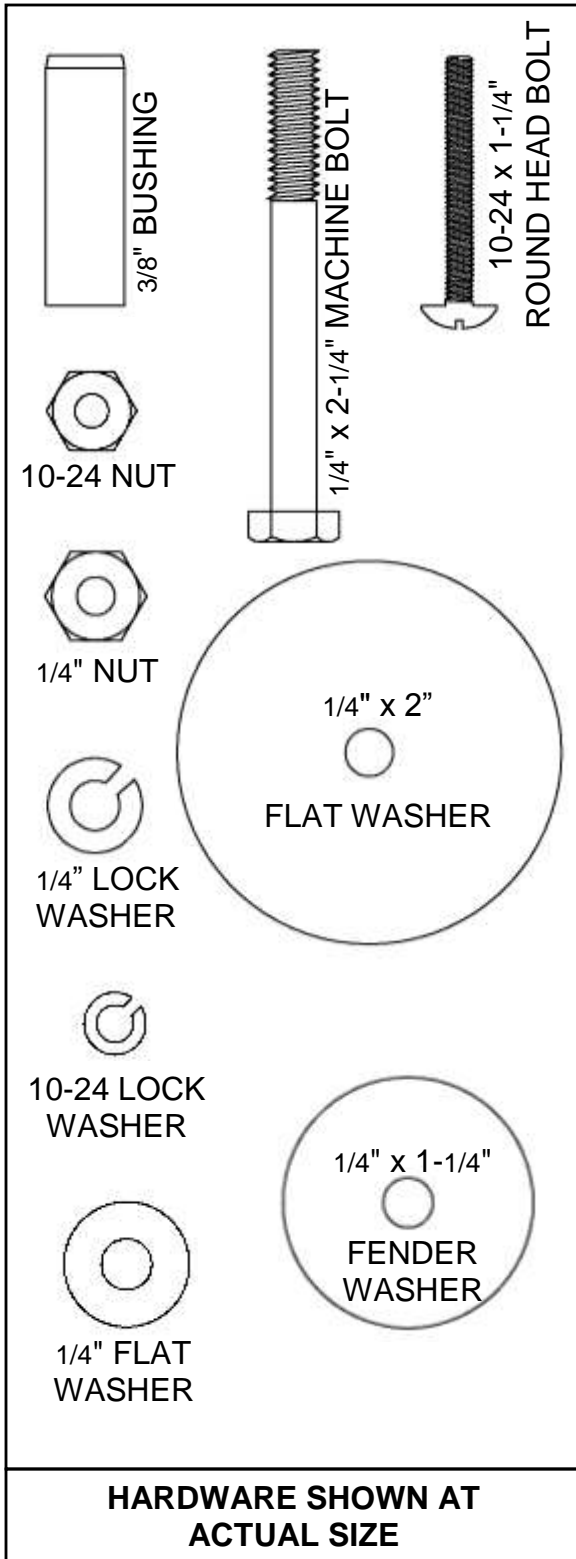

Photo # 5.37(b)

STEP SIX

Stabilizer Installation

Required Items: Stock Stabilizer Bag, Stock Radius Rods, Parts for Bushing Installation from Step Three (1/4" nut, 1/4" x 3-1/4" machine bolt, 1/4" nut and two 1/4" x 1-1/4" fender washers), Tools



Stabilizer Installation
(Legend Area Highlighted)

Stabilizer Bushing Sub-Assembly

*See Tech Tip E24.1

- 6.1 Place 1/4" x 1-1/4" fender washer on the 1/4" x 3-1/4" machine bolt from Step Three. See legend for location of holes.
- 6.2 Place bushing with flat end toward washer over the 1/4" x 3-1/4" machine bolt.
- 6.3 Insert machine bolt assembly through the top or bottom of floorboard with beveled end of bushing against floorboard and press through floorboard at stabilizer bolt location.

Stabilizer Bushing Sub-Assembly Continued

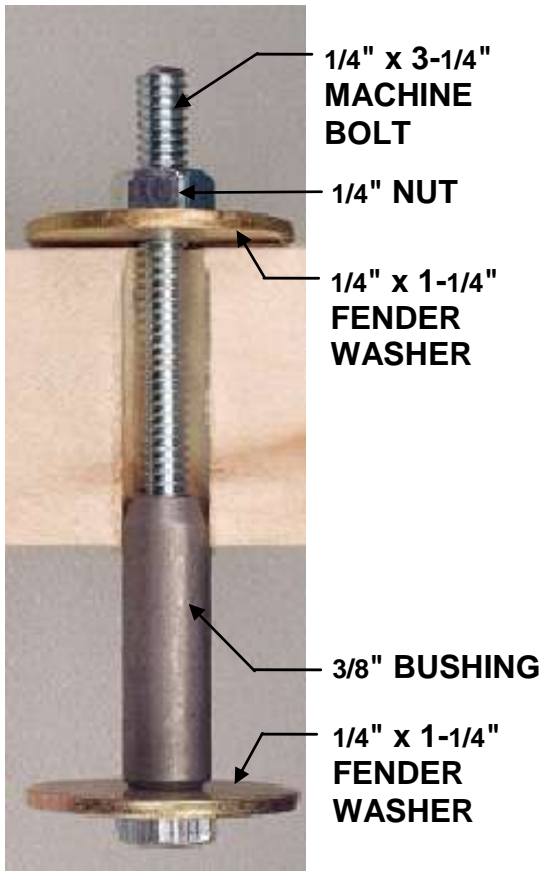

Photo # 6.5

- 6.4 Place a 1/4" x 1-1/4" fender washer on the 1/4" x 3-1/4" machine bolt against floorboard.
- 6.5 Install 1/4" nut on 1/4" x 1-1/4" fender washer. See Photo # 6.5
- 6.6 Tighten machine bolt bushing assembly until bushing end is flush with floorboard.
- 6.7 Remove 1/4" nut, machine bolt and washers. See Photo # 6.7
- 6.8 Repeat Steps 6.1 through 6.7 for second stabilizer bushing location.
- 6.9 Save 1/4" nut, 1/4" x 3-1/4" machine bolt and two 1/4" x 1-1/4" fender washers for possible future use.

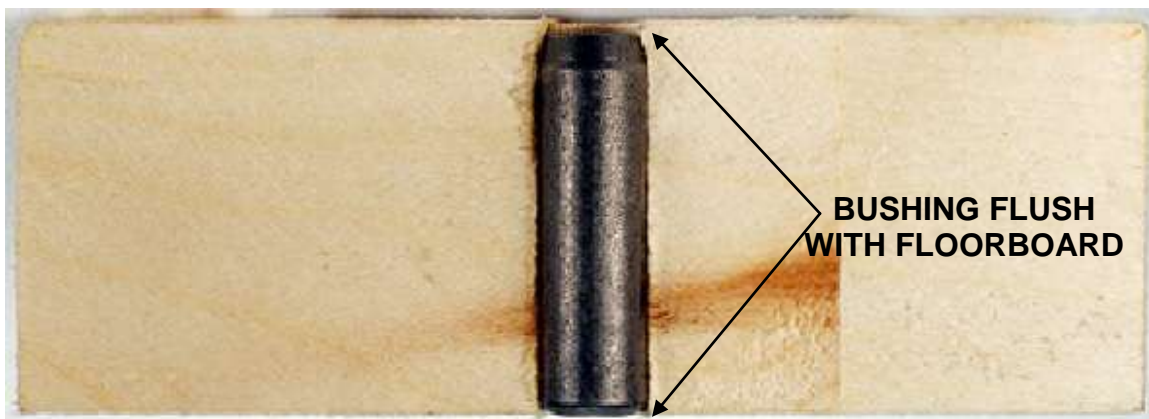

Photo # 6.7

Stock Radius Rod Sub-Assembly at Floorboard

- 6.10 Place 1/4" x 2" flat washer on the 1/4" x 2-1/4" machine bolt.
- 6.11 Insert assembly through bottom of floorboard at a stabilizer bushing location and press through the floorboard.
- 6.12 Place 1/4" x 1-1/4" fender washer on the machine bolt.
- 6.13 Place two 1/4" flat washers on 1/4" x 1-1/4" fender washer.
- 6.14 Place slotted end of a Stock radius rod on 1/4" flat washers. See Photo # 6.14
- 6.15 Place a 1/4" flat washer on Stock radius rod.
- 6.16 Place 1/4" lock washer on 1/4" flat washer.
- 6.17 Install 1/4" nut over 1/4" lock washer. See Photo # 6.17
- 6.18 **Do not completely tighten.** Further adjustments to occur in future Step Fourteen.
- 6.19 Repeat above Steps 6.10 through 6.18 for the second Stock radius rod.

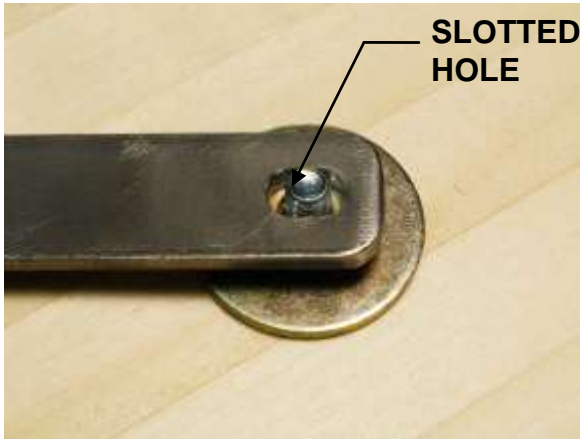

Photo # 6.14

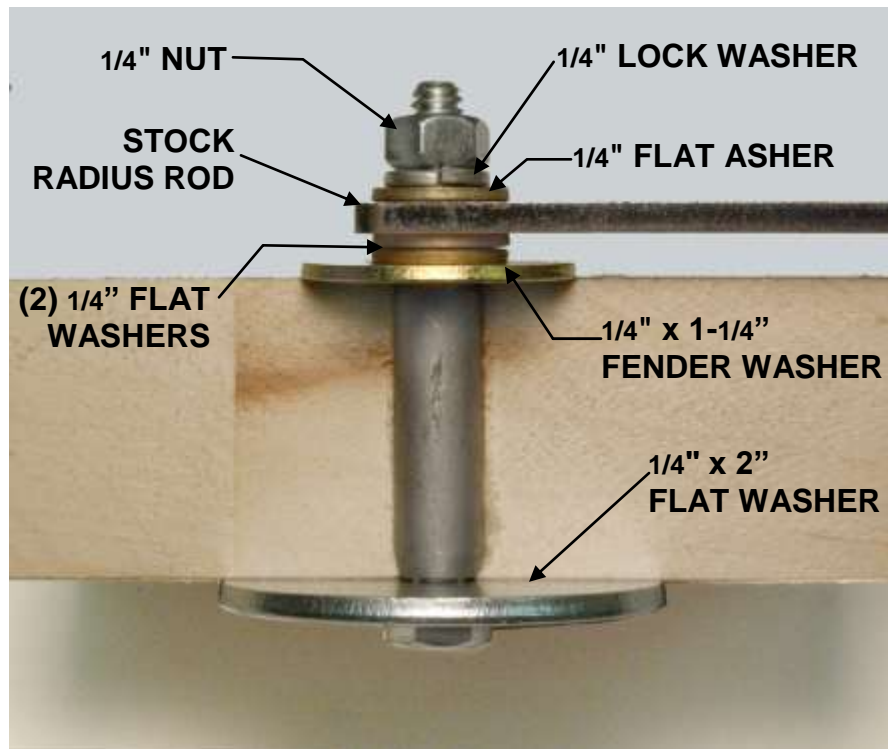

Photo # 6.17

Stock Radius Rod Sub-Assembly at Rear Axle

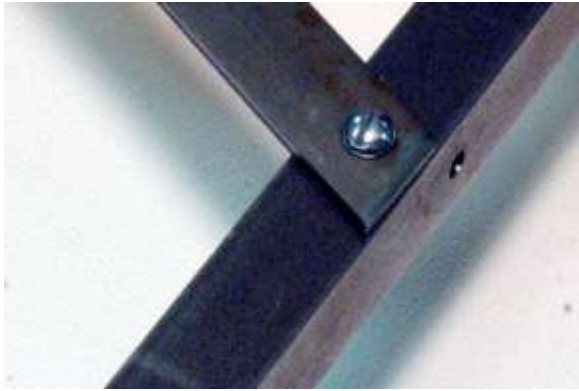

Photo # 6.21
(Bottom view of axle/Stock radius bar)

- 6.20 Align the angle end of the Stock radius rod on bottom of the axle square stock over the stabilizer bolt hole.
- 6.21 Place 10-24 x 1-1/4" round head bolt through the Stock radius rod and up through the axle. See Photo # 6.21
- 6.22 Place 10-24 lock washer on the 10-24 x 1-1/4" round head bolt.
- 6.23 Install 10-24 nut on 10-24 lock washer. **Do not completely tighten.** Further adjustments to occur in future Step Fourteen.
- 6.24 Repeat Steps 6.20 through 6.23 for second Stock radius rod to axle assembly. See Photo # 6.24



Photo # 6.24

STEP SEVEN

Brake Pad Installation

Required Items: Brake Pad Bag, Plunger, Tools

Brake Pad Installation

***See Tech Tip E24.6**

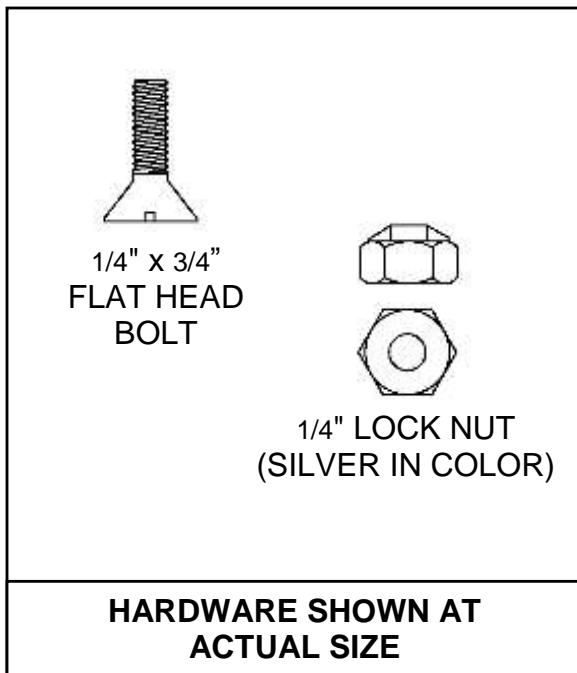

- 7.1 Insert one 1/4" x 3/4" flat head bolt through each hole of the brake pad. Either side of the brake pad may be used. See Photo # 7.1
- 7.2 Align bolts in brake pad with holes in flat bottom of the plunger and insert.
- 7.3 Place a 1/4" lock nut (silver in color) on 1/4" x 3/4" flat head bolt.
- 7.4 Tighten assembly. It is recommended that approximately an eighth of the 1/4" x 3/4" flat head bolt (or three threads) is exposed. The 1/4" x 3/4" flat head bolt will be recessed in the bottom of the brake pad. See Photo # 7.4
- 7.5 Repeat Steps 7.1 through 7.4 for other three bolt locations. See Photo # 6.24



**Photo # 7.1
(Brake Pad)**

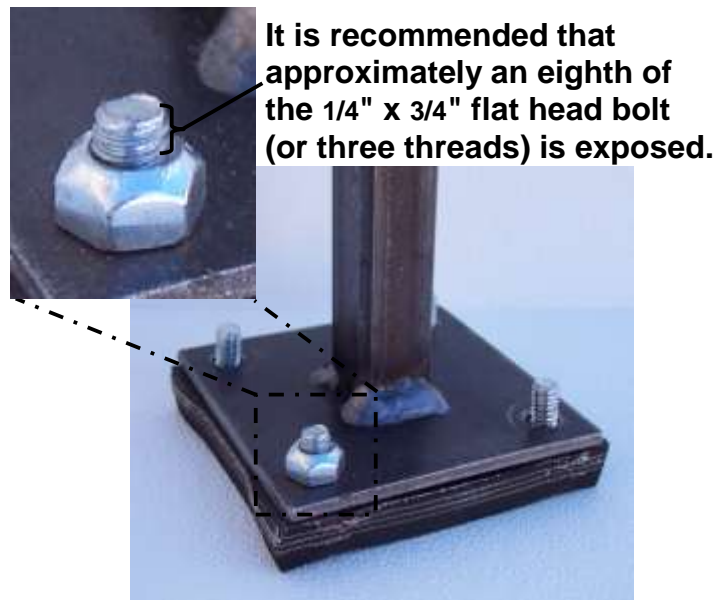

**Photo # 7.4
(Brake Pad/Plunger Assembly)**

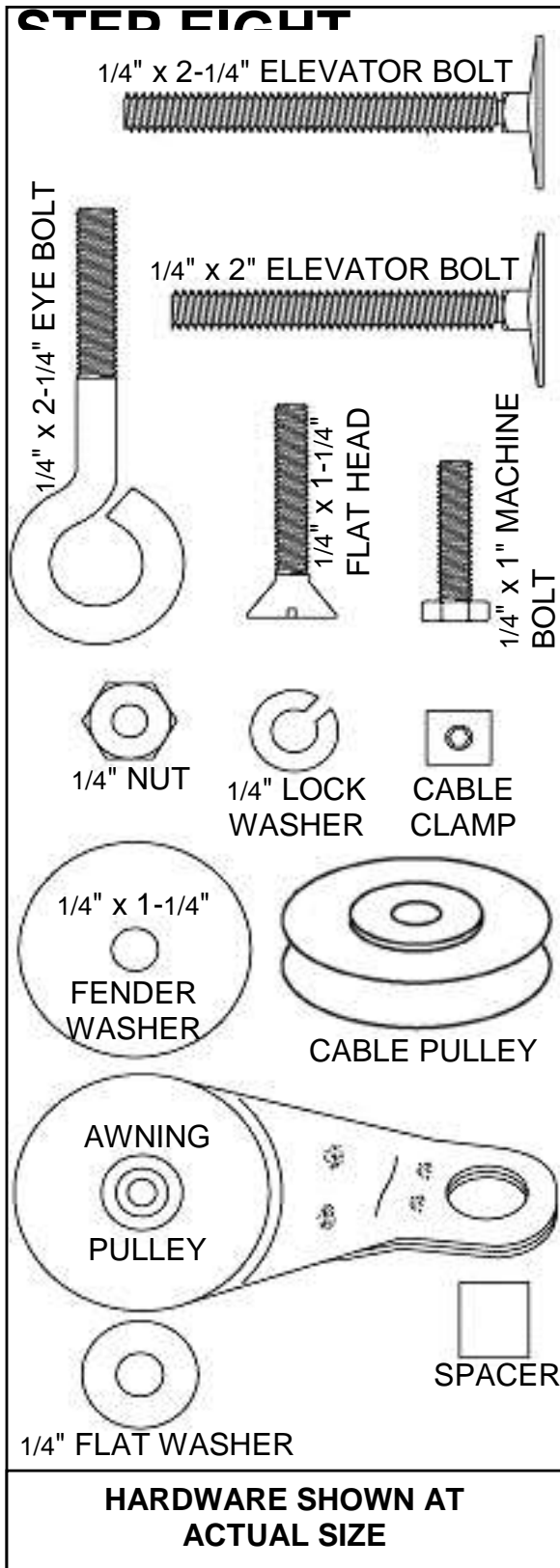

Floorboard, Brake Pad/Plunger Assembly ing, Tape (provided by others), Tools

Brake Pedal Hinge Sub-Assembly

- 8.1 Align the four hinge holes with the brake pedal. Top of the wood brake pedal has rounded corners and the bottom is straight. The fifth hole located at the rounded corner is for brake pedal eyebolt installation.
- 8.2 Insert 1/4" x 1-1/4" flat head bolt through brake pedal and through one of the four hinge holes.
- 8.3 Install 1/4" lock washer on 1/4" x 1-1/4" flat head bolt.
- 8.4 Install 1/4" nut on 1/4" washer. **Do not completely tighten.** See Photo # 8.4
- 8.5 Repeat Steps 8.2 through 8.4 for other three bolts.
- 8.6 Tighten nuts until bolt heads are flush with face of brake pedal.

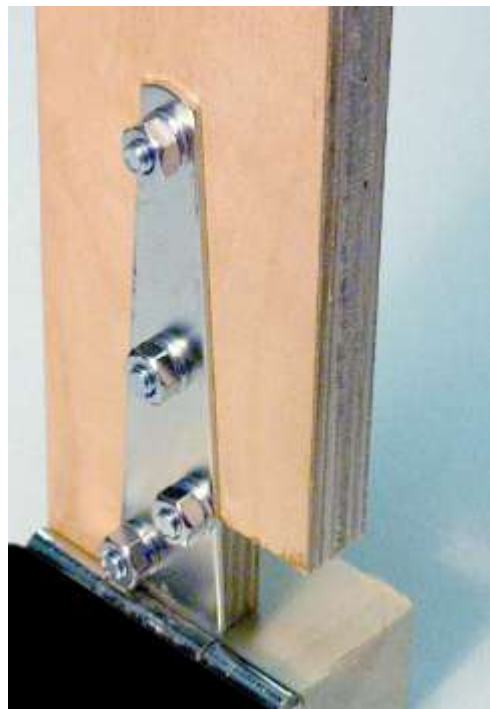

Photo # 8.4
(Partial image shown for clarity)



Photo # 8.12
(Eyebolt will face rear of car)

Brake Pedal Eyebolt Sub-Assembly

- 8.7 Install 1/4" nut on 1/4" x 2-1/4" eyebolt. Tighten nut to the end of threads on eyebolt.
- 8.8 Place 1/4" x 1-1/4" fender washer on the eyebolt.
- 8.9 Insert eyebolt assembly through the hole in the wood brake pedal on side opposite hinge.
- 8.10 Place 1/4" x 1-1/4" fender washer on the brake pedal eyebolt bolt assembly.
- 8.11 Install 1/4" lock washer on 1/4" x 1-1/4" fender washer.
- 8.12 Install 1/4" nut on 1/4" lock washer. Tighten eyebolt assembly. See Photo # 8.12



Brake Assembly Installation
(Legend Area Highlighted)

Brake Pedal Hinge Sub-Assembly at Floorboard

***See Tech Tip E24.3**



Photo # 8.18

- 8.13 Align the two outer holes of the brake pedal hinge with holes in floorboard at brake pedal location (center hole of hinge not used). See legend for location of holes.
- 8.14 Insert one 1/4" x 2" elevator bolt through the floorboard bottom at a brake pedal hole location and press through the floorboard and brake pedal hinge hole.
- 8.15 Place 1/4" lock washer on 1/4" x 2" elevator bolt.
- 8.16 Install 1/4" nut on 1/4" lock washer. **Do not completely tighten.**
- 8.17 Repeat Steps 8.13 through 8.16 for second bolt.
- 8.18 Tighten both nuts until bolts are drawn in flush with bottom of floorboard. See Photo # 8.18

Cable Pulley Sub-Assembly at Brake/Steering Mount

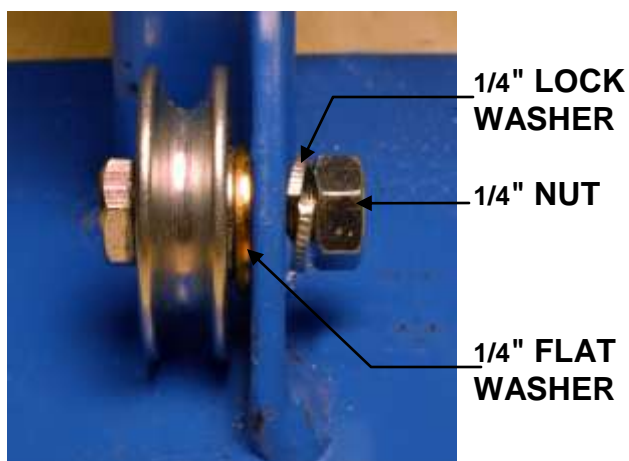

Photo # 8.24



Photo # 8.26
(Steering wheel and steering cables not shown for clarity)

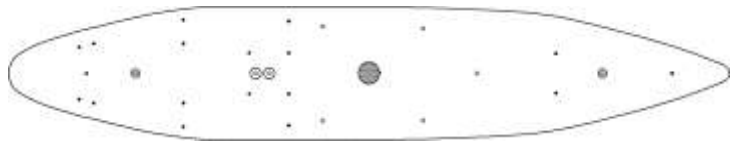

Photo # 8.30

- 8.19 Insert 1/4" x 1" machine bolt through cable pulley.
- 8.20 Place 1/4" flat washer on 1/4" x 1" machine bolt.
- 8.21 Insert 1/4" x 1" machine bolt with cable pulley and flat washer through hole in the left side of the vertical plate of the brake/steering mount.
- 8.22 Place 1/4" lock washer on the machine bolt assembly.
- 8.23 Install 1/4" nut on 1/4" lock washer.
- 8.24 Tighten assembly. Cable pulley shall spin freely. See Photo # 8.24

Plunger Sub-Assembly

- 8.25 Install 1/4" nut on 1/4" x 2-1/4" eyebolt. Tighten nut to end of threads on eyebolt.
- 8.26 Insert square tube end of brake plunger assembly through bottom of floorboard at large round hole of brake/steering mount and push through top of brake/steering mount. See Photo # 8.26
- 8.27 Place brake spring on brake plunger.
- 8.28 Compress brake spring coil and insert eyebolt assembly through hole of plunger (eyebolt faces rear of car).
- 8.29 Place 1/4" lock washer on the eyebolt assembly.
- 8.30 Install 1/4" nut on 1/4" lock washer. See Photo # 8.30
- 8.31 Tighten eyebolt assembly.
- 8.32 Push assembly down several times to ensure smooth operation.



Awning Pulley Installation
(Legend Area Highlighted)

Awning Pulley Sub-Assembly

- 8.33 Insert one 1/4" x 2-1/4" elevator bolt through the floorboard bottom at awning pulley hole location. See legend for location of hole.
- 8.34 Place 1/4" x 1-1/4" fender washer on the elevator bolt on top of the floorboard.
- 8.35 Place spacer on 1/4" x 1-1/4" fender washer.
- 8.36 Place awning pulley hole on spacer.
- 8.37 Place 1/4" flat washer on awning pulley.
- 8.38 Place 1/4 lock washer on 1/4" flat washer.
- 8.39 Install 1/4" nut on 1/4" lock washer.
- 8.40 The awning pulley swings freely and should be pointed toward the front of the car. See Photo # 8.40
- 8.41 Tighten nut until bolt is drawn flush with bottom of floorboard.

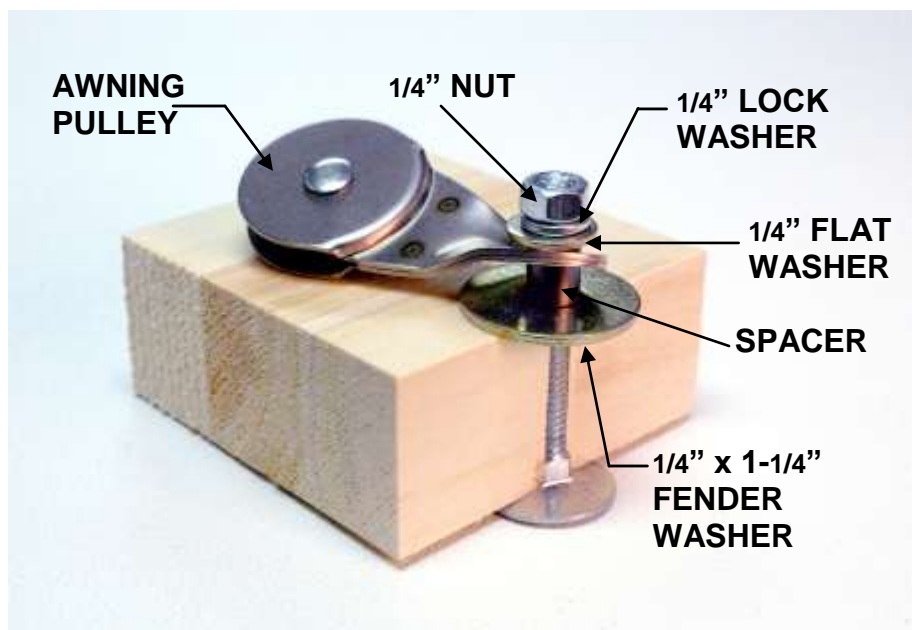

Photo # 8.40

Brake Cable Sub-Assembly

***See Tech Tip E24.5**

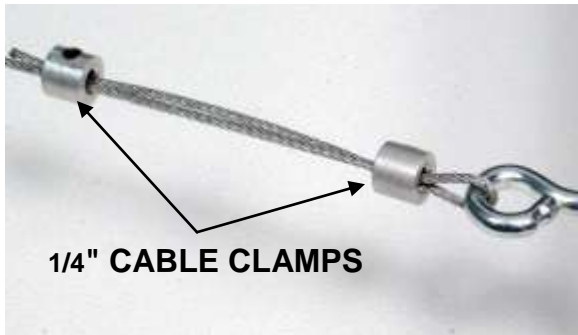

Photo # 8.44



Photo # 8.46

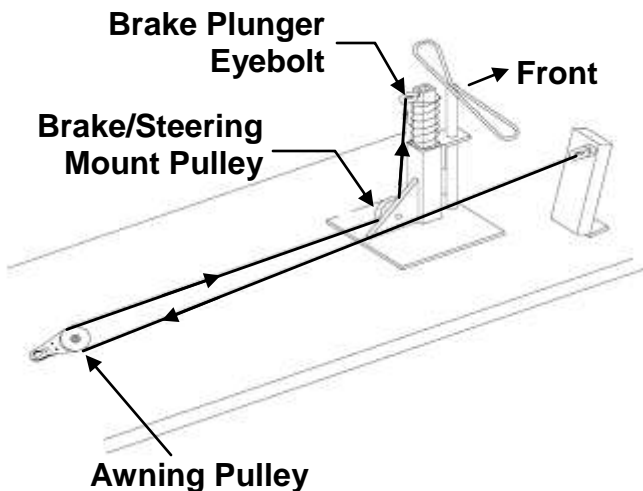

Figure # 8.49

- 8.42 Slide two cable clamps on one end of the brake cable.
- 8.43 Thread end of brake cable (approximately six inches) through the brake pedal eyebolt creating a loop around eyebolt.
- 8.44 Thread cable back through the two cable clamps. See Photo # 8.44
- 8.45 Tighten cable clamps with a 5/64" Allen Wrench.
- 8.46 Thread other end of brake cable through awning pulley and continue through cable pulley at brake/steering mount. See Photo # 8.46
- 8.47 Slide two cable clamps on the cable and continue the cable up through brake plunger eyebolt.
- 8.48 Insert loose end of the cable back through both cable clamps creating a loop around the eyebolt.
- 8.49 Pull loose end of cable tight and tighten cable clamps with a 5/64" Allen Wrench. See Figure # 8.49
- 8.50 Apply pressure to brake pedal and check for smooth operation of brake plunger. Lubrication of the plunger shaft and adjustment of the brake cable may be required. When brake is applied, brake plunger should extend sufficiently to the ground surface to stop the car.
- 8.51 Tighten all cable clamps securely.
- 8.52 Excess cable length may be removed by cutting. To avoid cable fraying it is recommended that solder be applied to a 1/4" +/- on either side of the proposed cut **prior to cutting**.
- 8.53 It is permitted to secure the loose ends of the cable with tape (provided by others).
- 8.54 Push brake pedal several times to ensure proper operation.

STEP NINE

Weight Bolt Installation

Required Items: Weight Bolt Bag, Floorboard, Weights (provided by others), Tools

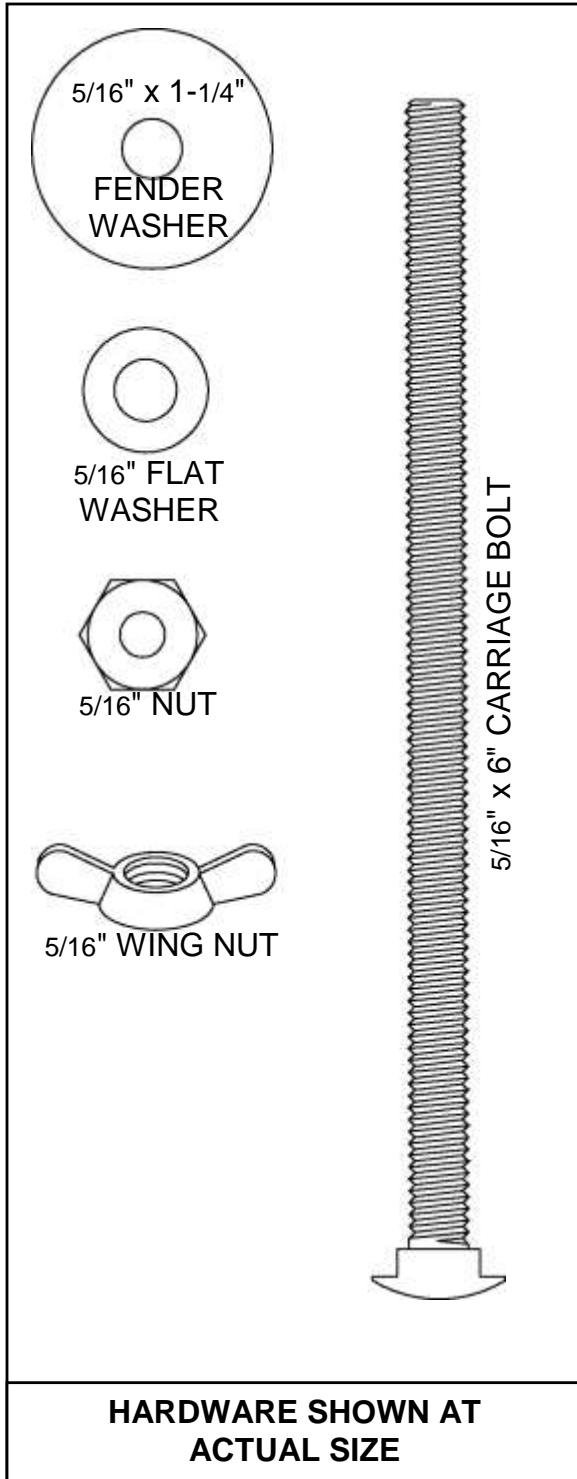

Weight Bolt Installation
(Legend Area Highlighted)

Weight Bolt Installation

- 9.1 Insert threaded end of 5/16" x 6" carriage bolt through the floorboard bottom at a weight hole location and press through the floorboard. See legend for location of holes.
- 9.2 Place a 5/16" flat washer on the 5/16" x 6" carriage bolt.
- 9.3 Install 5/16" nut on 5/16" flat washer.
- 9.4 Tighten bolt assembly.
- 9.5 Repeat Steps 9.1 through 9.4 for second bolt location.
- 9.6 These adjustable weight bolt assemblies are required.
- 9.7 See Tech Tips E20 – Optional Weights.

Weight Bolt Installation Continued

- 9.8 Place owner provided weights as needed on either, or both, of the 5/16" x 6" carriage bolts.
- 9.9 Place 5/16" x 1-1/4" fender washer on owner provided adjustable weight on both bolts.
- 9.10 Install 5/16" wing nut on 5/16" x 1-1/4" fender washer of both bolts. See Photo # 9.10
- 9.11 Tighten wing nuts. **Note that 5/16" x 1-1/4" fender washer and 5/16" wing nut must be installed even if weight is not used.**
- 9.12 See Tech Tips E20 – Optional Weights.

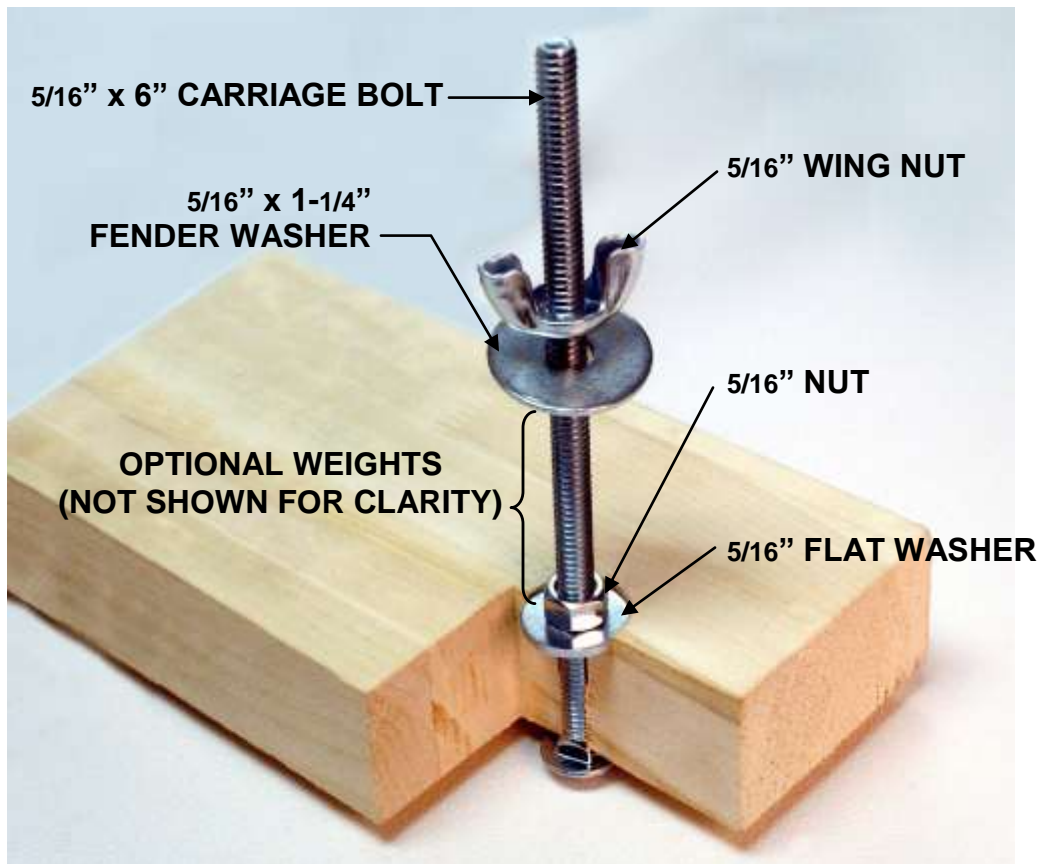
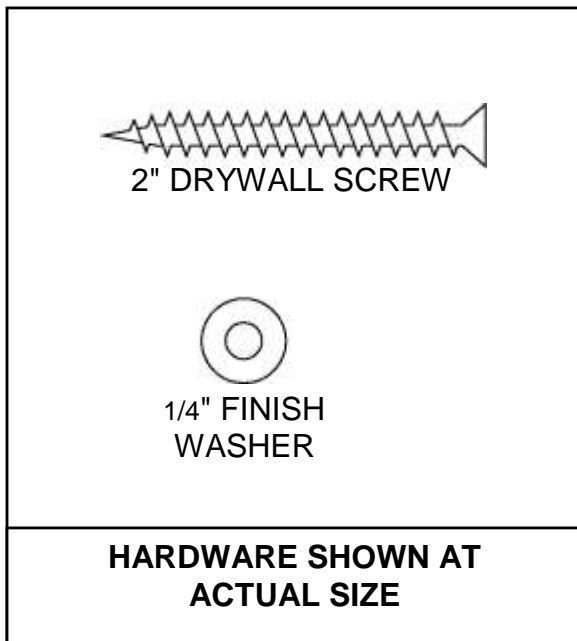

Photo # 9.10

STEP TEN

Airfoil Installation

Required Items: Airfoil Bag, Airfoils, Floorboard Assembly, Tools



Front Axle Airfoil Installation

- 10.1 Slide airfoil over the front axle square stock. Airfoil must not extend into the spindle (round stock) portion of the axle. See Photo # 10.1
- 10.2 Place a 2" drywall screw through a 1/4" finish washer.
- 10.3 Insert 2" drywall screw with 1/4" finish washer through rear surface of axle square stock. Tighten assembly. Recommend hand driver only. See Photo # 10.3
- 10.4 Repeat Steps 10.2 through 10.3 for the second attachment.
- 10.5 Repeat Steps 10.1 through 10.4 for second front axle airfoil.
- 10.6 No painting or covering the airfoils.

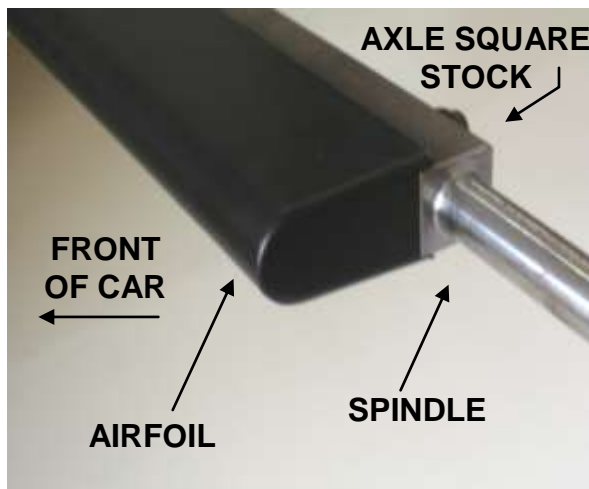

Photo # 10.3



Rear Axle Airfoil Installation



Photo # 10.1

- 10.7 Slide airfoil over the rear axle square stock. Airfoil must not extend into the spindle (round stock) portion of the axle. See Photo # 10.6
- 10.8 Place a 2" drywall screw through a 1/4" finish washer.
- 10.9 Insert 2" drywall screw with 1/4" finish washer through rear surface of axle square stock. Tighten assembly. Recommend hand driver only. See Photo # 10.8a and 10.8b
- 10.10 Repeat Steps 10.7 through 10.8 for the second attachment.
- 10.11 Repeat Steps 10.6 through 10.9 for second rear axle airfoil.
- 10.12 No painting or covering of the airfoils.

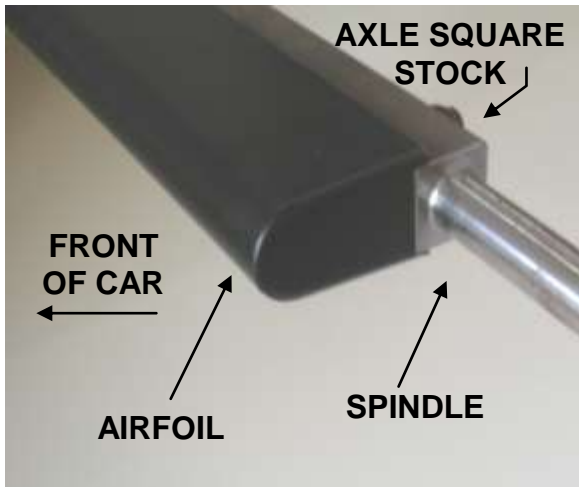

Photo # 10.6



STEP ELEVEN

Wheel Kit Installation

Required Items: Wheel Kit Bag, Z-Glas™ Wheels (purchased separately), Tools

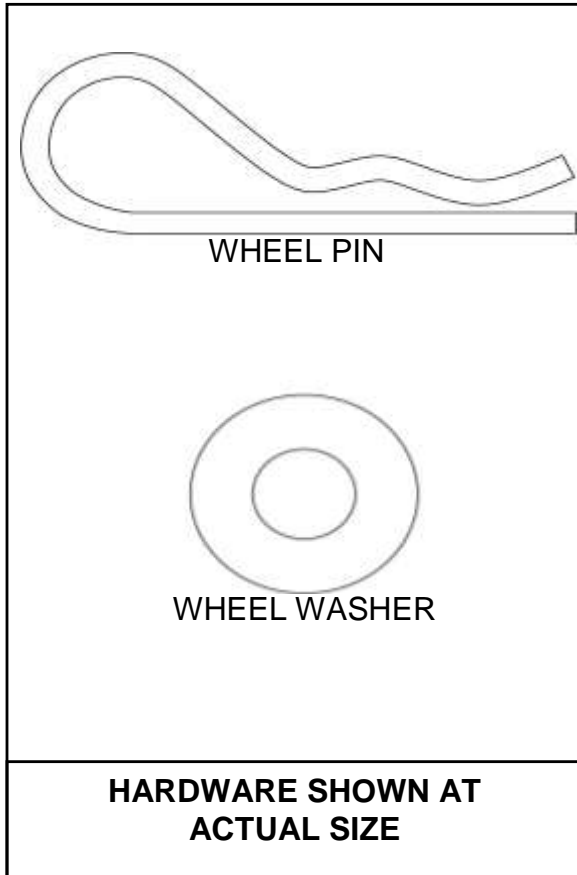

Wheel Kit Installation

- 11.1 Place a Z-Glas™ wheel (purchased separately) on an axle spindle.
- 11.2 Place a wheel washer on the axle spindle with the Z-Glas™ wheel.
- 11.3 Install wheel pin from front of axle through horizontal hole in axle spindle. See Photo # 11.3 Round portion of wheel pin shall face the front of the car.
- 11.4 Repeat Steps 11.1 through 11.3 for the other three wheels.

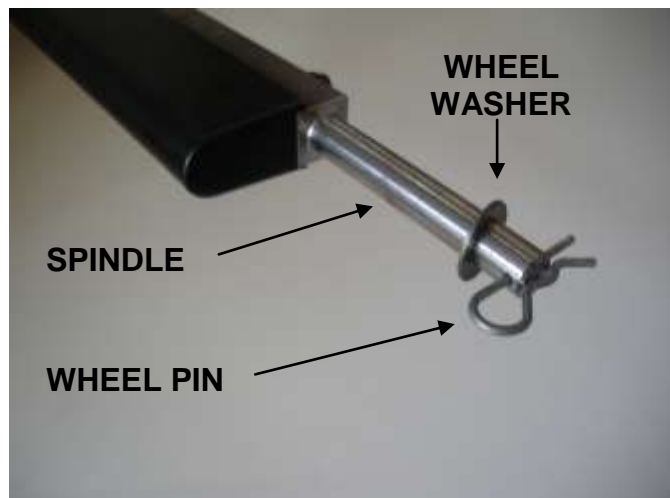
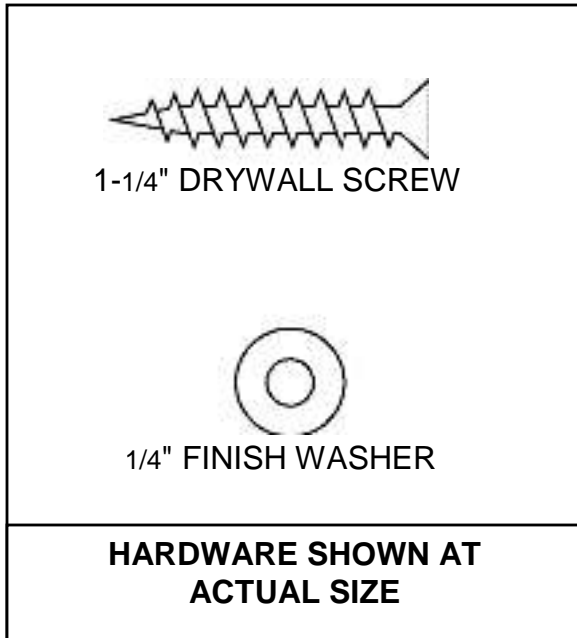

**Photo # 11.3
(Wheel not shown for clarity)**

STEP TWELVE

Shell Installation

Required Items: Body Mounting Bag, Foam, Shell, Floorboard Assembly (completed to this point), Adhesive and Tape (provided by others), Tools



Front Foam Sub-Assembly

- 12.1 Determine the front center point of the shell cockpit and temporarily mark on top shell. This will establish the center of the foam.
- 12.2 Temporarily mark the center of the long dimension of the foam.
- 12.3 Apply adhesive (provided by others) to the surfaces per adhesive manufacturer's instructions.
- 12.4 Being sure to keep the top of the foam flush with the top of the shell, apply the foam to the front inner lip of the cockpit starting in the center and working outward on both sides. **Foam must be installed full dimension and may not be cut or altered.** See Photo # 12.4
- 12.5 Use tape (provided by others) to temporarily clamp foam until adhesive is set.
- 12.6 See Tech Tips E22 – Cockpit Foam.

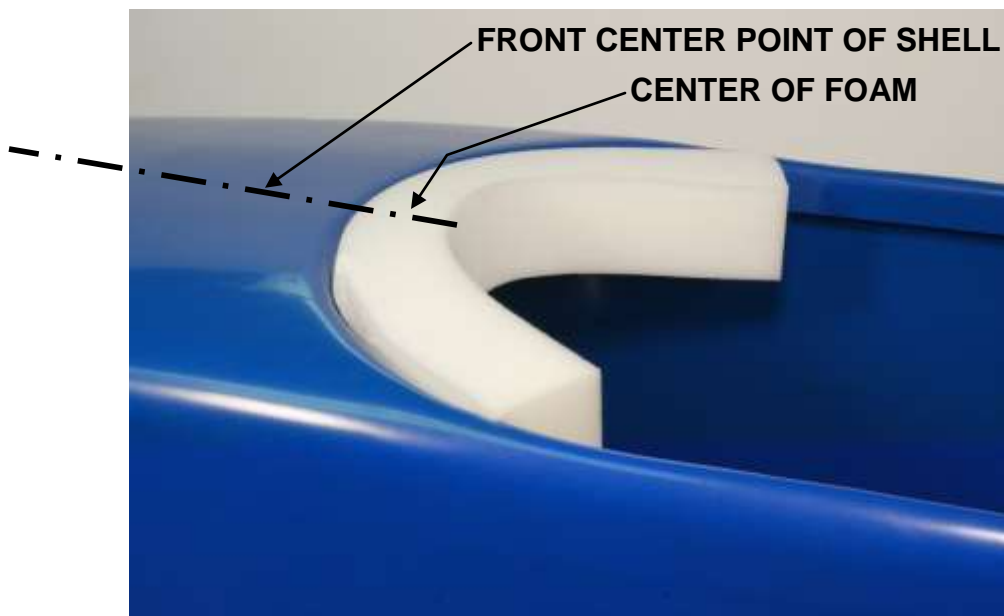
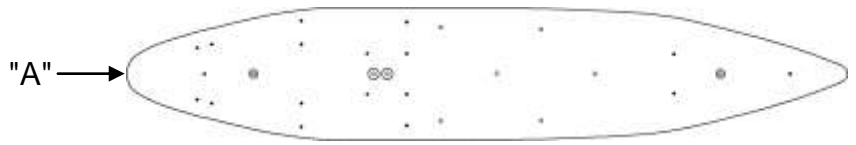

Photo # 12.4



Shell Installation
 (Legend Area Highlighted – axles and other hardware not shown for clarity)

Shell Installation Sub-Assembly

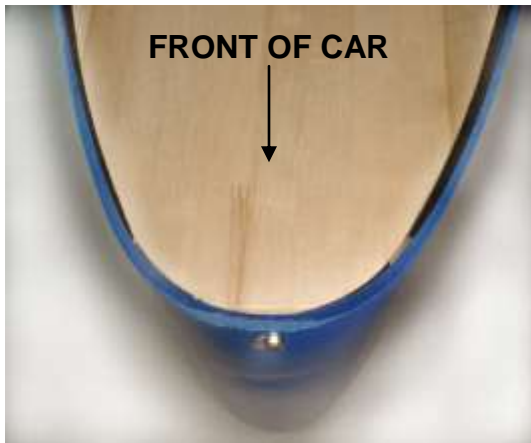

Photo # 12.11
(Bottom view of floorboard and shell)

- 12.7 Support floorboard off floor with two support boards wider than the floorboard width. Boards need to be the same thickness.
- 12.8 Lower shell over floorboard carefully slipping steering cables through slots at each side of the shell until shell is flush with bottom of floorboard.
- 12.9 Insert a 1-1/4" drywall screw through a 1/4" finish washer.
- 12.10 Insert the first screw/washer assembly through location "A" located at the front center of the car. **Note that the hole for this location is not pre-drilled.** See floorboard legend location "A".
- 12.11 Tighten the assembly until the nose of shell is flush to the front of the floorboard. No gap is permitted between shell and floorboard at the nose of the car. See Photo # 12.11
- 12.12 Adjust shell bottom to be flush with bottom of floorboard. Shell may be raised up to 1/2" in the rear only.
- 12.13 Insert another 1-1/4" drywall screw through a 1/4" finish washer.
- 12.14 Insert screw/washer assembly through any other shell hole of the car.
- 12.15 Tighten screw/washer assembly until the shell is tight to the floorboard.
- 12.16 Repeat Steps 12.13 through 12.15 until all holes in the shell are filled with screw/washer assemblies.
- 12.17 Check for clearance at axles and steering cable openings; axle and steering cable openings may be trimmed to ensure clearance.

STEP THIRTEEN

Signage, Lettering & Decoration

Required Items: All-American Soap Box Derby Decals, Signage, Lettering and Decoration (provided by others)

Signage, Lettering & Decoration

- 13.1 Specific areas of the shell are restricted as to the signage, lettering and decoration permitted. See Photos # 13.1 Top and Side Views
- 13.2 No signage, lettering and/or decoration may cover any screw attachments or body openings.
- 13.3 Section A: All-American Soap Box Derby Number*
 - This decal is only necessary to be put in place at the All-American Soap Box Derby World Championship.
- 13.4 Section B: Title/National Sponsor(s)*
 - This decal (or these decals) must be put in place for all Local Races, Rally Races and for the All-American Soap Box Derby World Championship.



Photo # 13.1 Top View

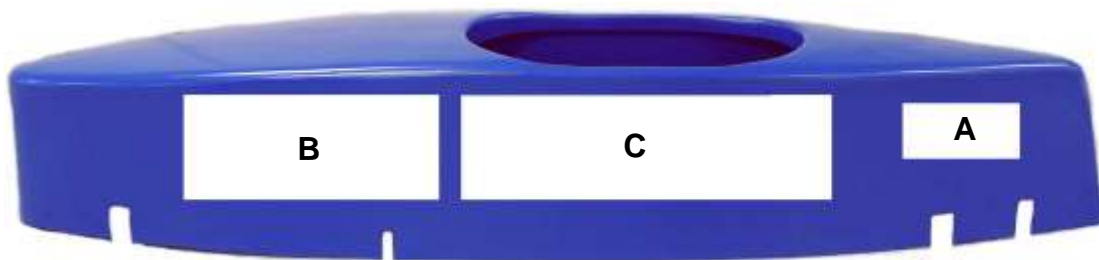

Photo # 13.1 Left Side View

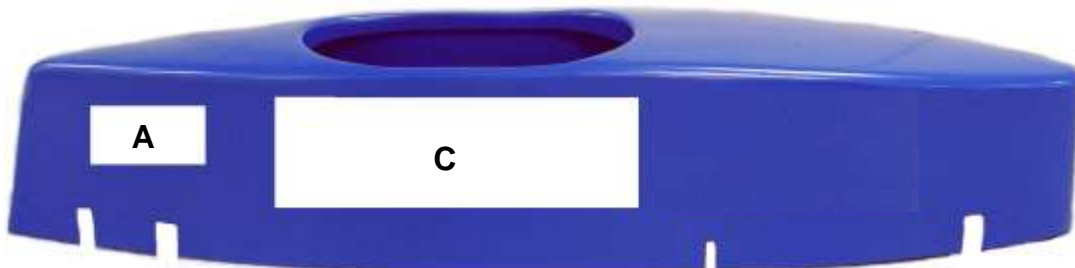

Photo # 13.1 Right Side View

Signage, Lettering & Decoration Continued

- 13.5 **Section C: Local Race City Organization OR Rally Region (previously “Rally District”)**
- This section is approximately thirty (30) inches wide and limited by the height of the shell.
 - At the All-American Soap Box Derby World Championship, this section must include the participant’s Local Race City Organization OR the Rally Region that the participant is representing. Lettering must be a minimum of 1-1/2” in height.
 - Optional signage, lettering and decoration in this section may include the car’s sponsor and/or the participant’s name.
- 13.6 **Section D: All-American Soap Box Derby Logo***
- This decal must be put in place for all Local Races, Rally Races and for the All-American Soap Box Derby World Championship.

**Decals provided by the International Soap Box Derby, Inc. or your Local Race City Organization*

STEP FOURTEEN

Axle Alignment & Triangulation

Required Items: Tape Measure and Triangulation Tool (provided by others), Tools

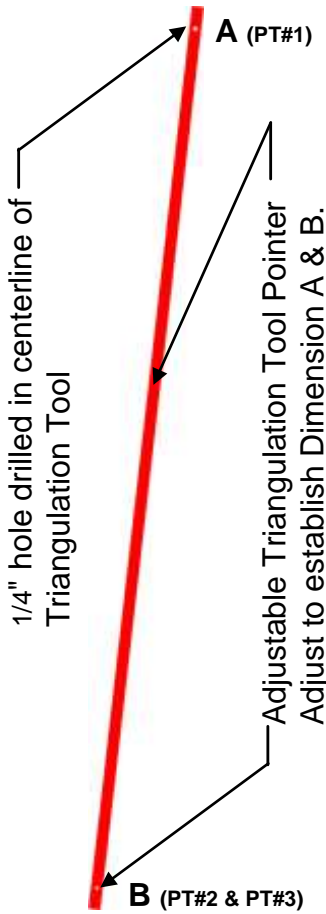

Figure # 14.2

Rear Axle Triangulation

- 14.1 The rear axle will need to be aligned to ensure that the car tracks properly in a straight line. This is known as Triangulation. Contact your local Derby Director for other available methods and assistance.
- 14.2 Obtain a long straight piece of wood or metal to create a "Triangulation Tool". Drill a 1/4" hole in one end and fix an adjustable pointer at the other end. See Figure # 14.2
- 14.3 Slide the 1/4" hole end over the front axle kingpin and use the adjustable pointer to establish Dimension B (PT#2 and PT#3) close to the end of the square stock. Mark locations PT#2 and PT#3.
- 14.4 Semi-tighten the rear stabilizer assembly and adjust the rear axle until both dimensions are exactly the same between PT#1 and PT#2, and PT#1 and PT#3. See Photo # 14.4
- 14.5 When both dimensions are equal, tighten the rear stabilizer assembly.
- 14.6 Check the measurement to ensure that it is equal.

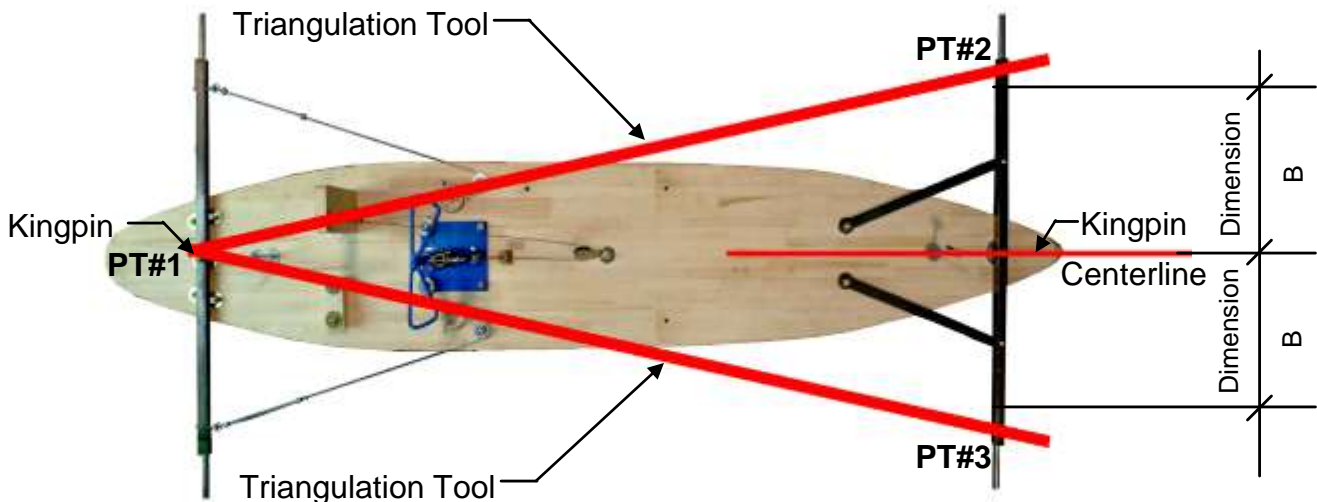

Photo # 14.4

Front Axle Alignment

Move eyebolt in or out to adjust cable tension.

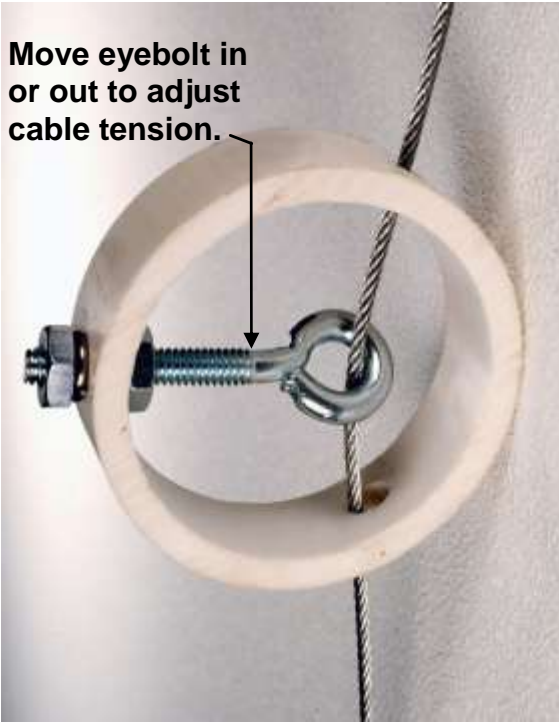

Photo # 14.8(a)
(Cable Adjuster Assembly)

- 14.7 The front axle will need to be aligned to ensure that the steering wheel is properly centered to allow the car to properly track in a straight line. Contact your local Derby Director for other available methods and assistance.
- 14.8 Center the steering wheel. Measure from the front edge of the rear axle to the front edge of the front axle on both sides. Tighten or loosen the steering cables at the cable adjuster eyebolt until Dimension C is exactly the same on both sides. See Photo # 14.8(a) and Photo # 14.8(b)
- 14.9 Tighten nuts on both sides of the cable adjuster.
- 14.10 Check the measurement to ensure that it is equal. The steering cable should be tight; however, not so tight that it bows the front axle.
- 14.11 Make sure that the axle turns in the same direction as the steering wheel.
- 14.12 Tighten all parts of the steering assembly as shown in Step Five.
- 14.13 Steering cable excess length may be cut off past the cable clamps. To avoid cable fraying it is recommended that solder be applied a 1/4" +/- on each side of the proposed cut **prior to cutting**.

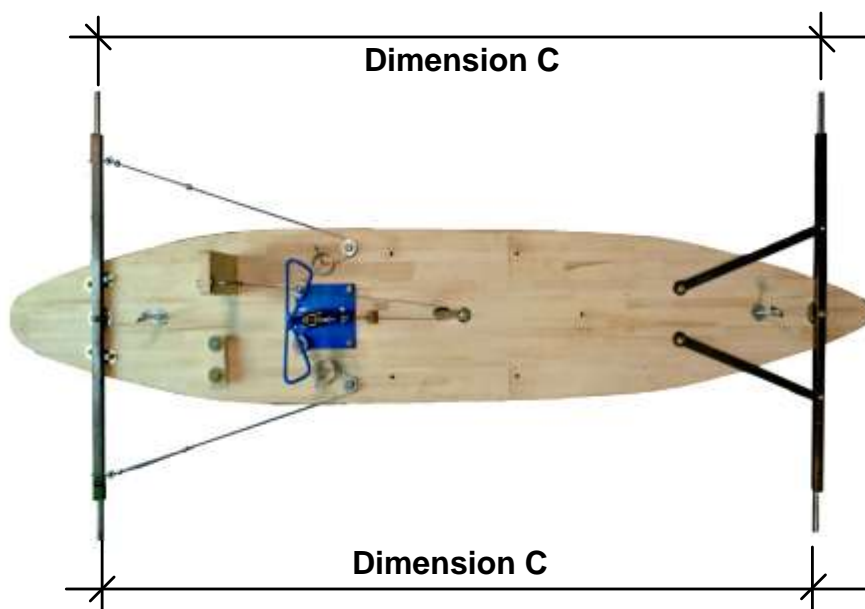

Photo # 14.8(b)

STEP FIFTEEN

Assembly Checklist

Carefully review the checklist below to ensure that you have completed the assembly of your car. The Installation Steps and Tech Tips are provided so that you may easily reference the work completed at each item identified.

- | | |
|--|-----------------|
| <input type="checkbox"/> Steering Stop Installation | (Step One) |
| <input type="checkbox"/> Foot Brace Installation | (Step Two) |
| <input type="checkbox"/> Kingpin Installation | (Step Three) |
| <input type="checkbox"/> Steering Hardware Installation | (Step Four) |
| <input type="checkbox"/> Steering Cabling Installation | (Step Five) |
| <input type="checkbox"/> Stabilizer Installation | (Step Six) |
| <input type="checkbox"/> Brake Pad Installation | (Step Seven) |
| <input type="checkbox"/> Brake Installation | (Step Eight) |
| <input type="checkbox"/> Weight Bolt Installation | (Step Nine) |
| <input type="checkbox"/> Airfoil Installation | (Step Ten) |
| <input type="checkbox"/> Wheel Kit Installation | (Step Eleven) |
| <input type="checkbox"/> Shell Installation | (Step Twelve) |
| <input type="checkbox"/> Signage, Lettering & Decoration | (Step Thirteen) |
| <input type="checkbox"/> Axle Alignment & Triangulation | (Step Fourteen) |
| <input type="checkbox"/> Optional Weights | (Tech Tip E20) |
| <input type="checkbox"/> Optional Finishes | (Tech Tip E21) |
| <input type="checkbox"/> Cockpit Foam | (Tech Tip E22) |
| <input type="checkbox"/> Alignment | (Tech Tip E23) |
| <input type="checkbox"/> Permitted Modifications | (Tech Tip E24) |

Congratulations on completing your car. You are now ready to race!

TECH TIP E20

Optional Weights (Provided by Others)

General Requirements

E20.1 The car may be increased to the maximum weight of 200 pounds (including the driver, car and Z-Glas™ wheels) by the addition of weights. The additional weight must be securely bolted through the floorboard and pass all requirements of the official inspection.

There are two types of weight:

- 1) Adjustable Weight
- 2) Fixed Weight

E20.2 Fixed and adjustable weight is available for purchase from the International Soap Box Derby, Inc.

E20.3 Weight may consist of wood or metal materials. Weight in the form of angles, channels, tees or other structural shapes are not permitted. If bar bell type weights are used, the large center hole must be filled or a dowel rod must be used until the weight fits securely on the weight 5/16" bolt.

E20.4 If 10 or less pounds of weight are used in a car, *all* of the weight must be adjustable.

E20.5 If more than 10 pounds of weight is used in a car, a combination of fixed and adjustable weight is permitted. However, at least 10 pounds of the weight *must be* adjustable (3-two pound, 3-one pound, and 2-eight ounce or any other combination).

E20.6 Weight may not be located between the original holes of the foot brace and the brake pedal back to the steering pulleys as shown in Photo # E20.6.

E20.7 A 1/8" clearance must be maintained between the weights, shell, axles, stabilizer assembly and the weight-free zone.

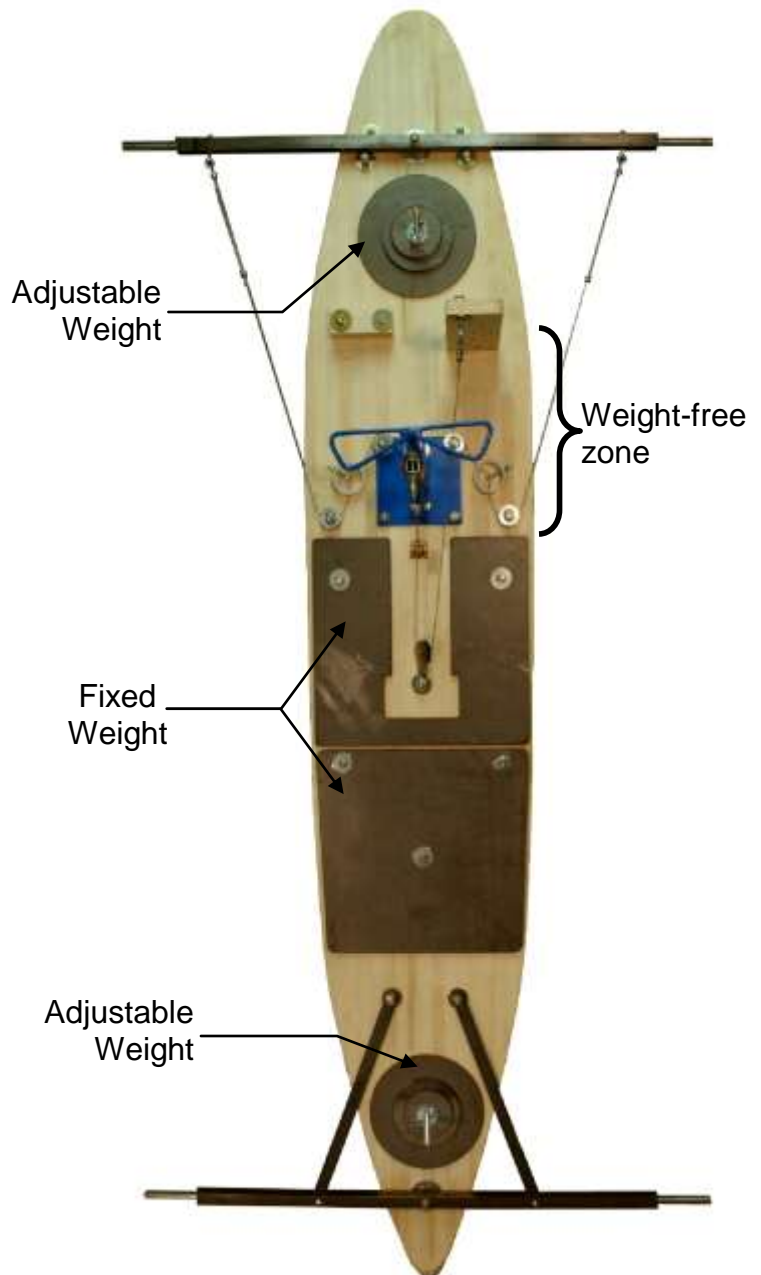

Photo # E20.6

General Requirements Continued

- E20.8 All weights must be easily removable with adequate bolt clearance. Weights must not:
- 1) Disconnect or remove any hardware components
 - 2) Conceal any components
 - 3) Be permanently attached to the car
 - 4) Be threaded on the weight bolt
 - 5) Be poured into the car
 - 6) Touch the side or other components of the car
 - 7) Be chained to the car

- E20.9 Weight materials must be painted and the weight of each piece clearly marked.

Adjustable Weights

- E20.10 Two locations are dedicated for the adjustable weight. The bolts for these locations were installed in Step Nine. These two bolts are the *only* location that adjustable weight will be placed. See floorboard legend. Adjustable weight height is limited only by the length of the bolt. The size of the adjustable weight is limited by the required 1/8" clearance to the shell, axles and stabilizer assembly and/or cannot exceed 12" lengthwise. See Photo # E20.10

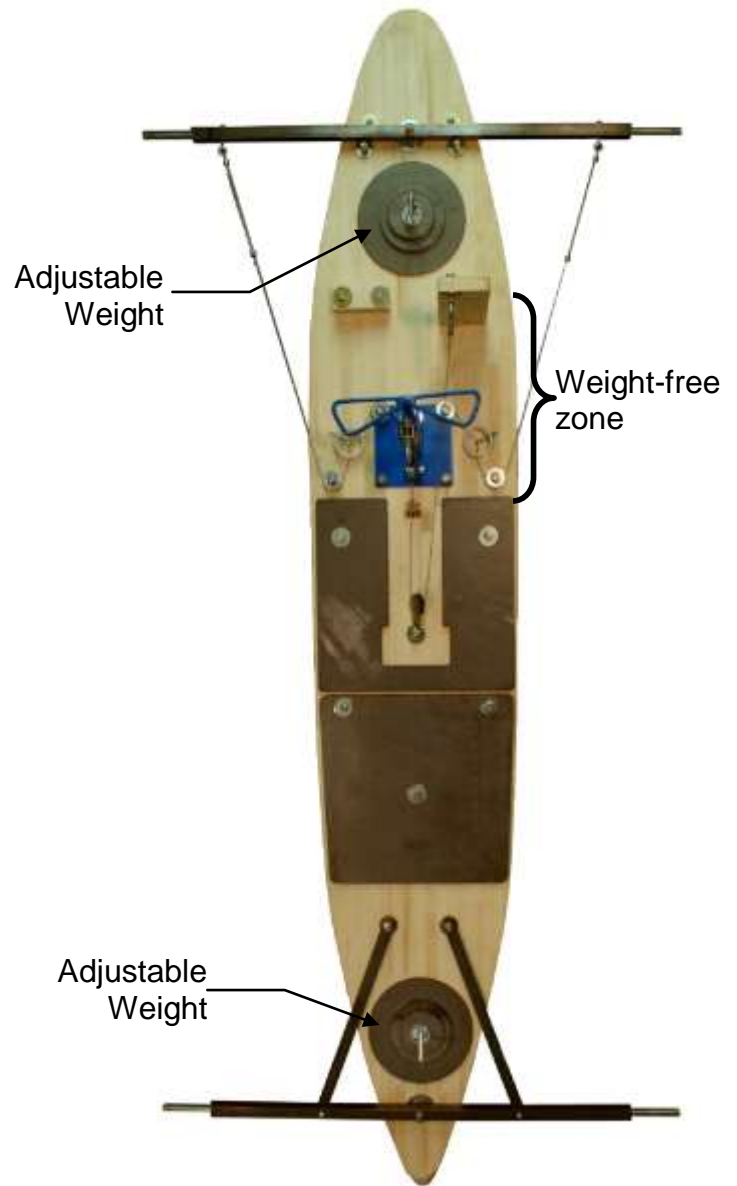
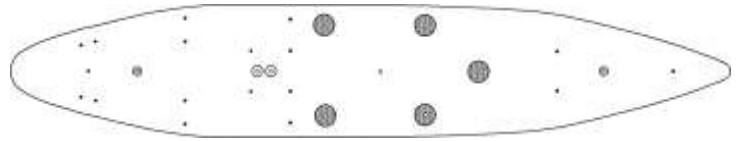

Photo # E20.10



Fixed Weight Bolt Installation
(Legend Area Highlighted)

Fixed Weight

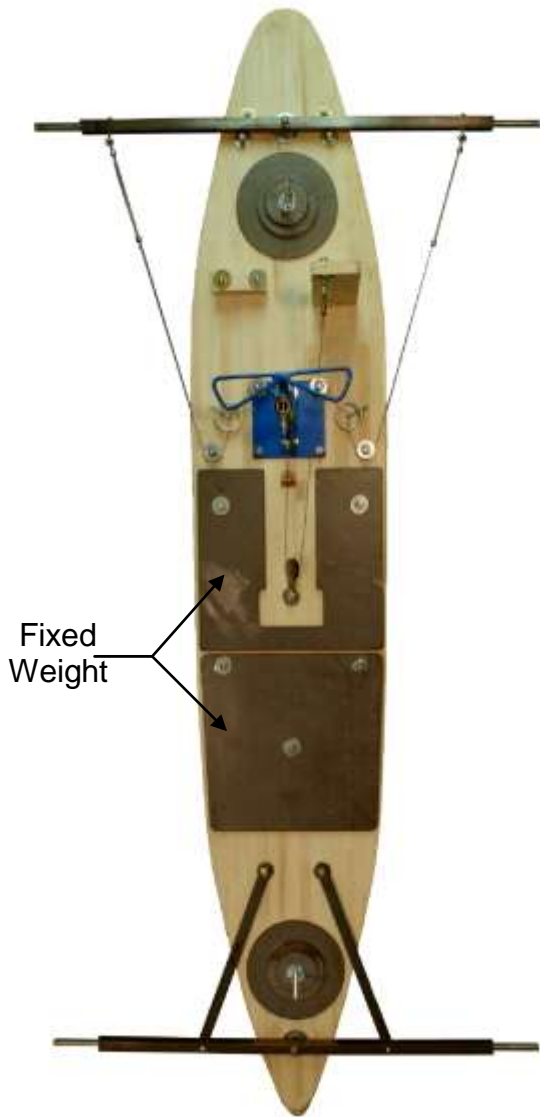

Photo # E20.11

E20.11 Five bolt holes in the center/seat location of the floorboard are dedicated to fixed weight only. These five bolt areas are the *only* location that fixed weight may be anchored. See legend above for location of holes. Any combination of bolt locations may be used, but each weight must be secured by a minimum of one bolt. See Photo # E20.11

E20.12 Fixed weight must not exceed a maximum height of 1-1/2" above the floorboard or exceed a 12" lengthwise dimension. Weight must be secured to prevent shifting or any type of movement with a 5/16" bolt, 5/16" x 1-1/4" fender washer and a 5/16" nut (provided by others).

E20.13 Added weight in the form of bars, plates or flat shapes are permitted but must not exceed 12" lengthwise, must stack evenly on each other in the car, and must not exceed a total height of 1-1/2". A minimum horizontal clearance of 1/8" must occur between the weights in the fixed weight area. Bolts under the driver must be trimmed flush to the top of the nut.

E20.14 See Photo # E20.14 for examples of adjustable and fixed weight.



Photo # E20.14
(Weight materials must be painted and the weight of each piece clearly marked.)

TECH TIP E21

Optional Finishes (Provided by Others)

Floorboard

- E21.1 All Stock floorboards engraved with the derby shield and 06 or earlier may be finished with tung oil. Floorboards engraved with the derby shield and 07 or later are pre-finished by the manufacturer. Particle floorboards are no longer legal in the Stock and Super Stock divisions. "SBP" branded floorboards may not be used after August 1st, 2011."SBP with shield" branded floorboards may not be used after August 1st, 2012. See photo E21.1a and E21.1b.



Photo E21.1a

Photo

See exception to phase out at http://aasbd.whitespace-creative.com/media/1652/floorboard_phase_out_and_airfoil_update.pdf

- E21.2 Only a thin coat of clear wax may be applied to the top, bottom and/or sides of the pre-finished floorboards. Please note that the machine marks on the sides of the floorboard shall remain. No finish build-up thickness shall occur.

Airfoils

- E21.3 No finish is required for the airfoils. The only optional finish materials permitted is:
- 1) A thin coat of clear wax

Shell

- E21.4 No paint finish is permitted for the shell. The only optional finish materials permitted, but not required, are:
- 1) Decorative permanent markers
 - 2) Self adhesive vinyl materials
 - 3) A thin coat of automotive-type wax
- E21.5 The materials used in the shell manufacturing may cause permanent markers to not properly adhere; therefore, caution is advised when using this optional finish.
- E21.6 The exterior surface of the car shell may be finished with solid sheets or decorative cutouts of self adhesive vinyl material applied in a single layer on the exterior. Exceptions:
- 1) If sheet adhesive vinyl material is used, all All-American Soap Box Derby and sponsor decals must be placed over the finished surface of the shell
 - 2a) The body of the car shall not be completely wrapped
 - 2b) The bottom 2" of shell may not be covered.
 - 2c) Top shell radius shall not be covered. Minimum separation of 2" required between side and top vinyl material.
 - 2d) Top of shell vinyl may not occur within 1" of cockpit opening.
 - 3) The total lengths of the car's sides may not be completely covered
 - 4) The nose of the car may not be covered. The nose is defined as the part of the car that comes in contact with the starting paddle (1-1/2" from the centerline with a total width of 3" in a horizontal and full height of the shell in the vertical direction).

- E21.7 The exterior shell may have automotive-type wax applied as a finish. Caution is advised as some waxes contain colorings that may stain the material.

Foam

- E21.8 Foam may be dyed using clothing dye.

TECH TIP E22

Cockpit Foam



Photo # E22.5

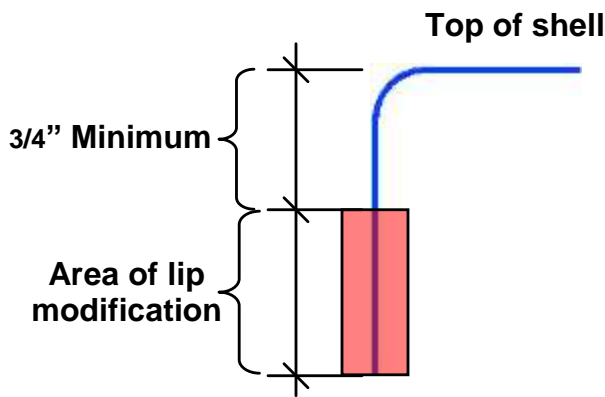

Figure # E22.6

Shell-Cockpit Opening Rear Foam

***See Tech Tip E24.7**

- E22.1 An additional foam piece may be installed in addition to the required foam shown in Step Twelve.
- E22.2 Determine the rear center point of the shell cockpit and temporarily mark on top shell. This will establish the center of the foam.
- E22.3 Temporarily mark the center of the long dimension of the foam.
- E22.4 Apply adhesive (provided by others) to the surfaces per adhesive manufacturer's instructions.
- E22.5 Being sure to keep the top of the foam flush with the top of the shell, apply the foam to the inner lip of the cockpit starting in the center and working outward on both sides. **Optional foam must be installed in full dimension and may not be cut or altered.** See Photo # E22.5

Shell-Cockpit Rear Lip

- E22.6 A portion of the shell's inner lip may be removed in an area starting 17-1/4" behind the front center of the cockpit opening continuing to the rear of the opening. A minimum of 3/4" of the lip must remain intact.

See Figure # E22.6 and Photo # E22.6

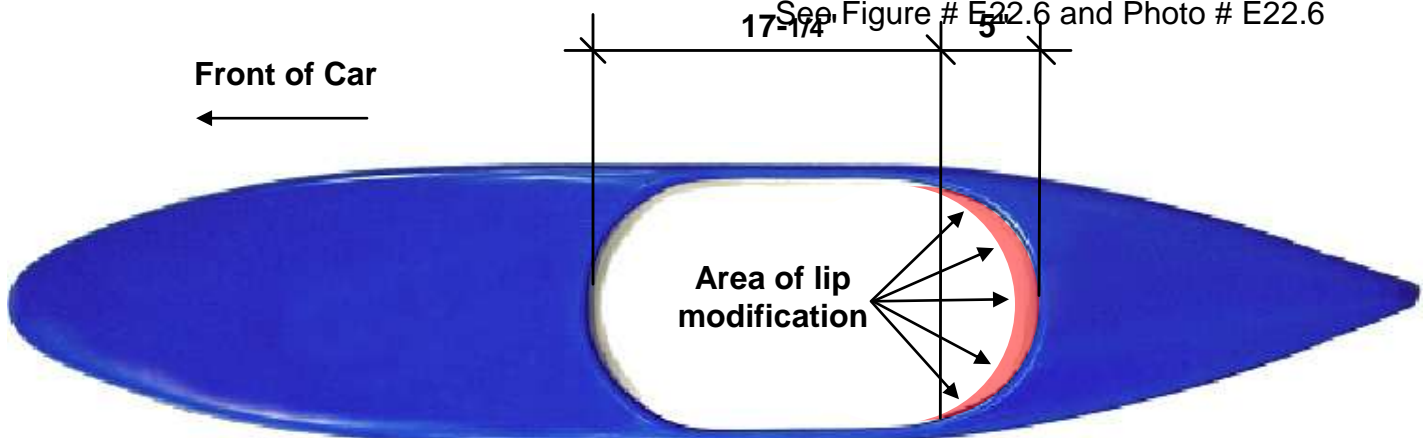

Photo # E22.6

TECH TIP E23

Alignment

Axle Alignment – Cross Bind Adjustment



Photo # E23.3
(Feeler Gauge Set)



Photo # E23.4

E23.1 Cross bind adjustment is used to create a parallel horizontal plane between the front and rear axles. A single shim placement at either the front or the rear axle, **not both**, may be installed to eliminate cross bind between the two axles. This procedure is offered as guidance but is not the only method available. Contact your local Derby Director for other available methods and assistance. See Photo # E23.1

E23.2 Elevate the floorboard and view the horizontal alignment of the front and rear axles from one end of the car. Determine if shimming is needed based on whether or not the axles are parallel.

E23.3 The permitted shim must be a single, complete, uncut, feeler gauge (set available at any automotive store). Shims are available in thickness starting at one thousandth of an inch (.001). **Only one shim may be used in a car.** See Photo # E23.3

E23.4 Install the single shim at the kingpin bolt assembly between floorboard and a washer or between two washers, all occurring below the axle bottom and at only one axle kingpin location. Small nails may be used to hold one or both ends of the feeler gauge in place. See Photo # E23.4

E23.5 Tighten all parts of the kingpin assembly as shown in Step Three.



Parallel Alignment



Non-Parallel Alignment (in need of Cross Bind Adjustment)

Figure # E23.1

Axle Alignment – Spindling

E23.6 Spindling is an optional adjustment of the spindle (round portion) of the axle to gain Toe or Camber Alignment.

This is an advanced procedure that requires specialized tools, knowledge, patience and extreme caution to ensure that the axles are not modified and declared disqualified. Contact your local Derby Director for methods and assistance.

See Figure # E23.6(a) and Figure # E23.6(b)

Top View of Axle showing Toe Alignment (Distorted for Clarity)

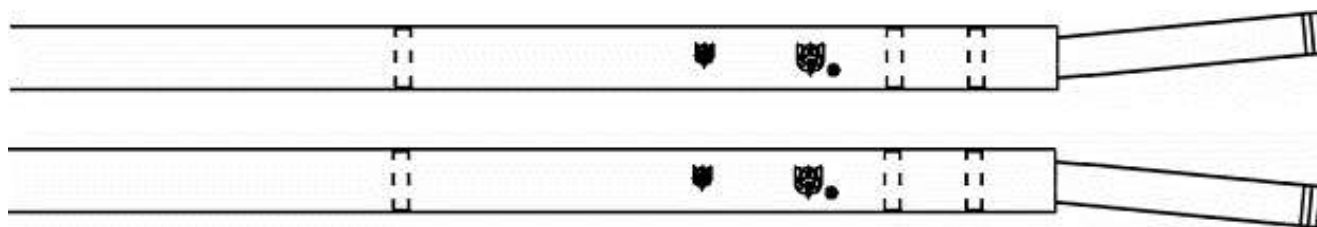

Figure # E23.6(a)
(Partial Front Axle (with all hardware removed) shown as an example only.
This figure can be used for both front and rear axles.)

Side View of Axle showing Camber Alignment (Distorted for Clarity)

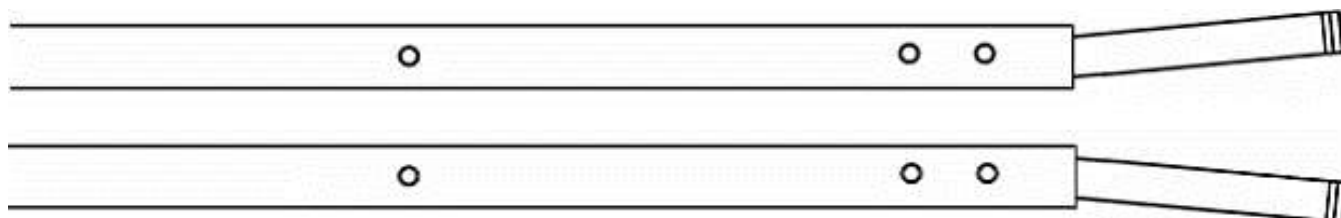

Figure # E23.6(b)
(Partial Front Axle (with all hardware removed) shown as an example only.
This figure can be used for both front and rear axles.)

TECH TIP E24

Permitted Modifications

Bushings

E24.1 None. The use of epoxy is no longer permitted.

Brake/Steering Mount

E24.2 Brake/steering mount may be moved **forward only** to accommodate a driver.

Brake Pedal and Foot Brace

E24.3 Brake pedal and foot brace may be moved forward or back to accommodate a driver.

Steering Wheel

E24.4 Steering wheel bowtie may face in either direction.

Cable Clamps

E24.5 Brake and steering cable may be double looped.

Brake Pad Installation

E24.6 The brake pad may be installed to the plunger using *both* a 1/4" lock washer and 1/4" nut (provided by others) instead of the 1/4" lock nut.

INDEX

Numbers after topic indicate instruction page number, not instruction step.

A		F	
Airfoil		Feeler Gauges	47
<i>Finishes</i>	44	Finishes	
<i>Installation</i>	32-33	<i>Airfoil</i>	44
Awning Pulley	28-29	<i>Floorboard</i>	44
Axle		<i>Foam</i>	45
<i>Alignment</i>	38-39	<i>Shell</i>	45
<i>Installation</i>	11	Foam, Cockpit	
Axle Eyebolt	16	<i>Installation</i>	35, 46
Axle Stop Assembly	7	Foot Brace	8
B		Floorboard Legend	6
Brake Pad	24	G	
Brake Pedal	25-26	Guidance	3-4
<i>Cable Clamps</i>	29	H	
<i>Cable Cutting</i>	29	Help	3-4
<i>Cable Installation</i>	29	Hinge, Brake Pedal	25-26
<i>Cable Pulley</i>	27	I	
<i>Eyebolt</i>	26	J	
<i>Hinge</i>	25-26	K	
<i>Spring</i>	27	Kingpin	
Brake/Steering Mount	12-14	<i>Kingpin Bolt Installation</i>	11
Bushing	9-10, 20-21	<i>Kingpin Location</i>	6, 9
Bushing Installation Parts	9	L	
C		Lettering	37
Cable Adjuster, Steering	16-19, 39	M	
Cable Clamps	18, 29	Markers	45
Cable Cutting	19, 29	Modifications	49
Cables, Brake	29	N	
Cables, Steering	17-18	O	
Checklist	40		
Cotter Pin	14		
Cross Bind Adjustment	47		
D			
Decoration	37, 44-45		
E			
Elevator Bolts	7-8, 12-13, 15		
E-mail	4		
Eyebolt	15-19, 25-27, 39		

P		
Paint		
<i>Airfoil</i>	44	
Plunger, Brake	24	
Pulley		
<i>Awning</i>	28-29	
<i>Cable</i>	12-13, 15, 27	
Q		
Questions	3-4	
R		
Rear Cockpit Foam	46	
S		
Shell		
<i>Decoration</i>	37, 45	
<i>Finish</i>	45	
<i>Installation</i>	36	
Shims	47	
Signage		
<i>ISBD Logo</i>	37	
<i>ISBD Number</i>	37	
<i>Local Sponsor</i>	37	
<i>National Sponsor</i>	37	
<i>Title Sponsor</i>	37	
Spindling Alignment	48	
Spring, Brake	27	
Stabilizer Assembly	20-23	
Steering Wheel	14	
Steering		
<i>Alignment</i>	38-39	
<i>Cable Clamps</i>	18-19	
<i>Cable Cutting</i>	19	
<i>Cable Installation</i>	17-19	
<i>Cable Pulley</i>	15	
Steering Stop	7	
Stock Radius Rod	22-23	
Supplies	5	
T		
Tape	29, 35	
Tech Tips	41-49	
Tools	5, 38	
Triangulation	38	
U		
V		
Vinyl Material	45	
W		
Wax	44-45	
Web Site(s)	3-4	
Weight		
<i>Adjustable</i>	47-48	
<i>Fixed</i>	47-49	
<i>Weight Free Zone</i>	47-48	
Weight Bolt Installation	31-32	
Wheels (Z-Glas™ Wheels)	35	
Wheel Pin	35	
Wheel Washer	35	
X		
Y		
Z		
Z-Glas™ Wheels		
Installation	35	